

FUEL INJECTION (FUEL SYSTEMS)

General Description

FUEL INJECTION (FUEL SYSTEMS)

1. General Description

A: SPECIFICATION

Fuel tank	Capacity	60 ℓ (15.9 US gal, 13.2 Imp gal)
	Location	Under rear seat
Fuel pump	Type	Impeller
	Shutoff discharge pressure	450 — 677 kPa (4.59 — 6.9 kgf/cm ² , 65.27 — 98.2 psi)
	Discharge flow	More than 145 ℓ (38.3 US gal, 31.9 Imp gal)/h [12 V at 300 kPa (3.06 kgf/cm ² , 43.5 psi)]
Fuel filter		Cartridge type

B: COMPONENT

1. INTAKE MANIFOLD

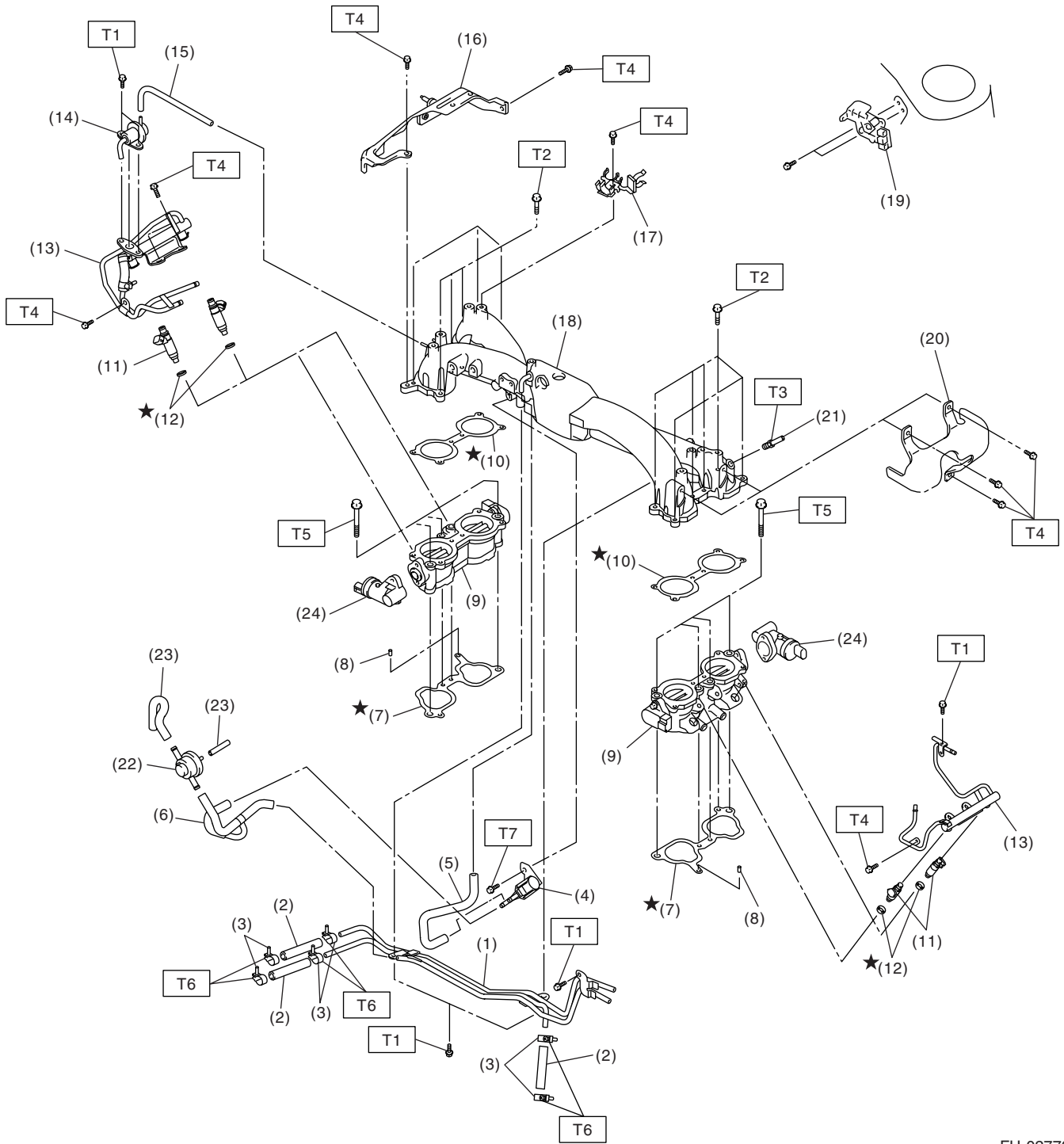

FU-02770

General Description

FUEL INJECTION (FUEL SYSTEMS)

(1) Fuel pipe ASSY	(12) Insulator	(22) Purge valve
(2) Fuel hose	(13) Fuel injector pipe	(23) Purge hose
(3) Clip	(14) Pressure regulator	(24) Tumble generator valve actuator
(4) Purge control solenoid valve	(15) Pressure regulator hose	
(5) Vacuum hose	(16) Fuel pipe protector RH	<hr/>
(6) Vacuum control hose	(17) Blow-by hose stay	Tightening torque: N·m (kgf-m, ft-lb)
(7) Intake manifold gasket	(18) Intake manifold	T1: 6.4 (0.65, 4.7)
(8) Guide pin	(19) Wastegate control solenoid valve ASSY	T2: 8.25 (0.84, 6.1)
(9) Tumble generator valve ASSY	(20) Fuel pipe protector LH	T3: 17 (1.73, 12.5)
(10) Tumble generator valve gasket	(21) Nipple	T4: 19 (1.94, 13.7)
(11) Fuel injector		T5: 25 (2.5, 18.1)
		T6: 1.25 (0.13, 0.94)
		T7: 16 (1.6, 11.6)

2. AIR INTAKE SYSTEM

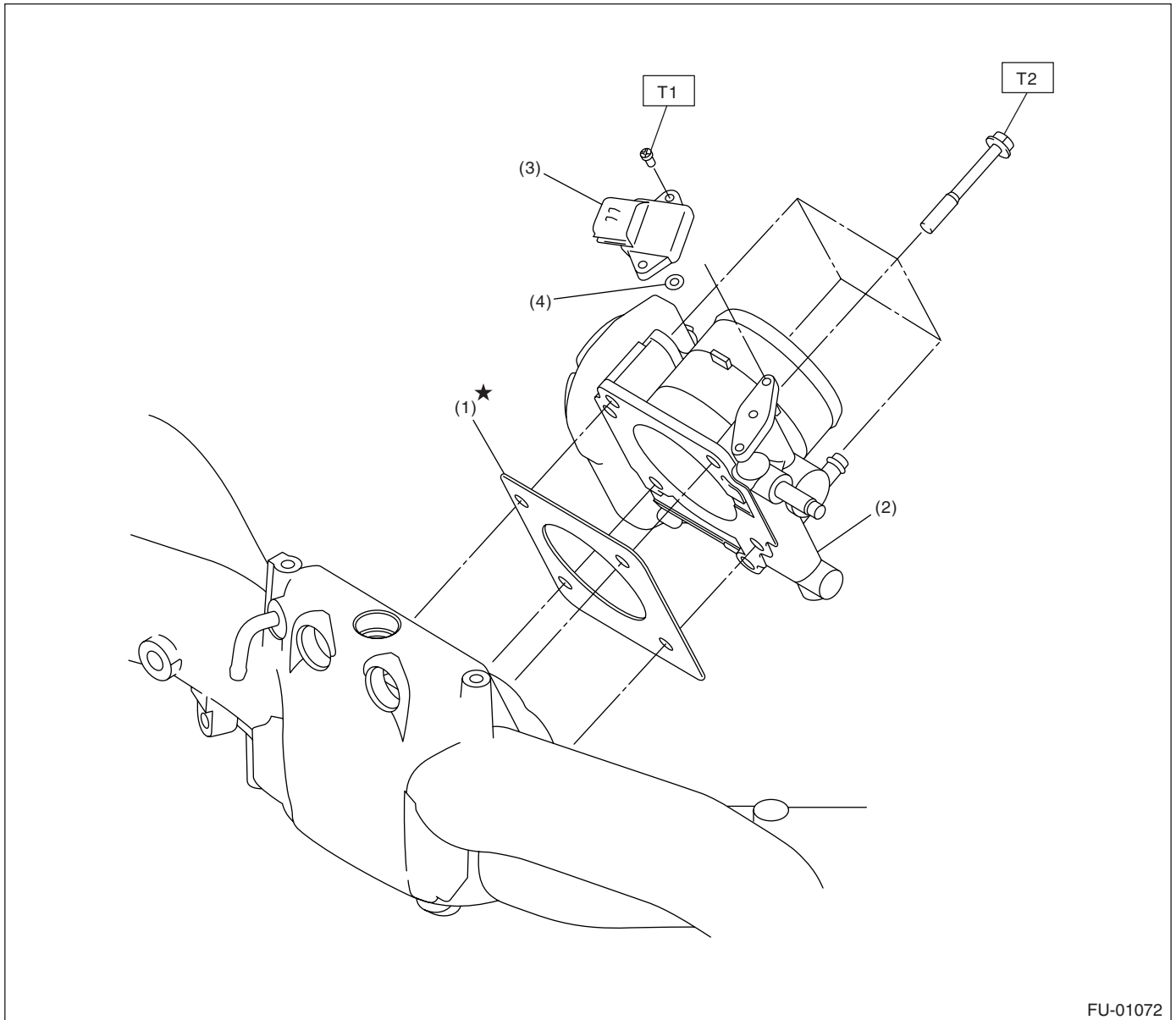

FU-01072

- (1) Gasket
- (2) Throttle body

- (3) Manifold absolute pressure sensor
- (4) O-ring

Tightening torque: N·m (kgf·m, ft·lb)

T1: 1.6 (0.16, 1.2)

T2: 8 (0.8, 5.8)

General Description

FUEL INJECTION (FUEL SYSTEMS)

3. CRANKSHAFT POSITION, CAMSHAFT POSITION AND KNOCK SENSORS

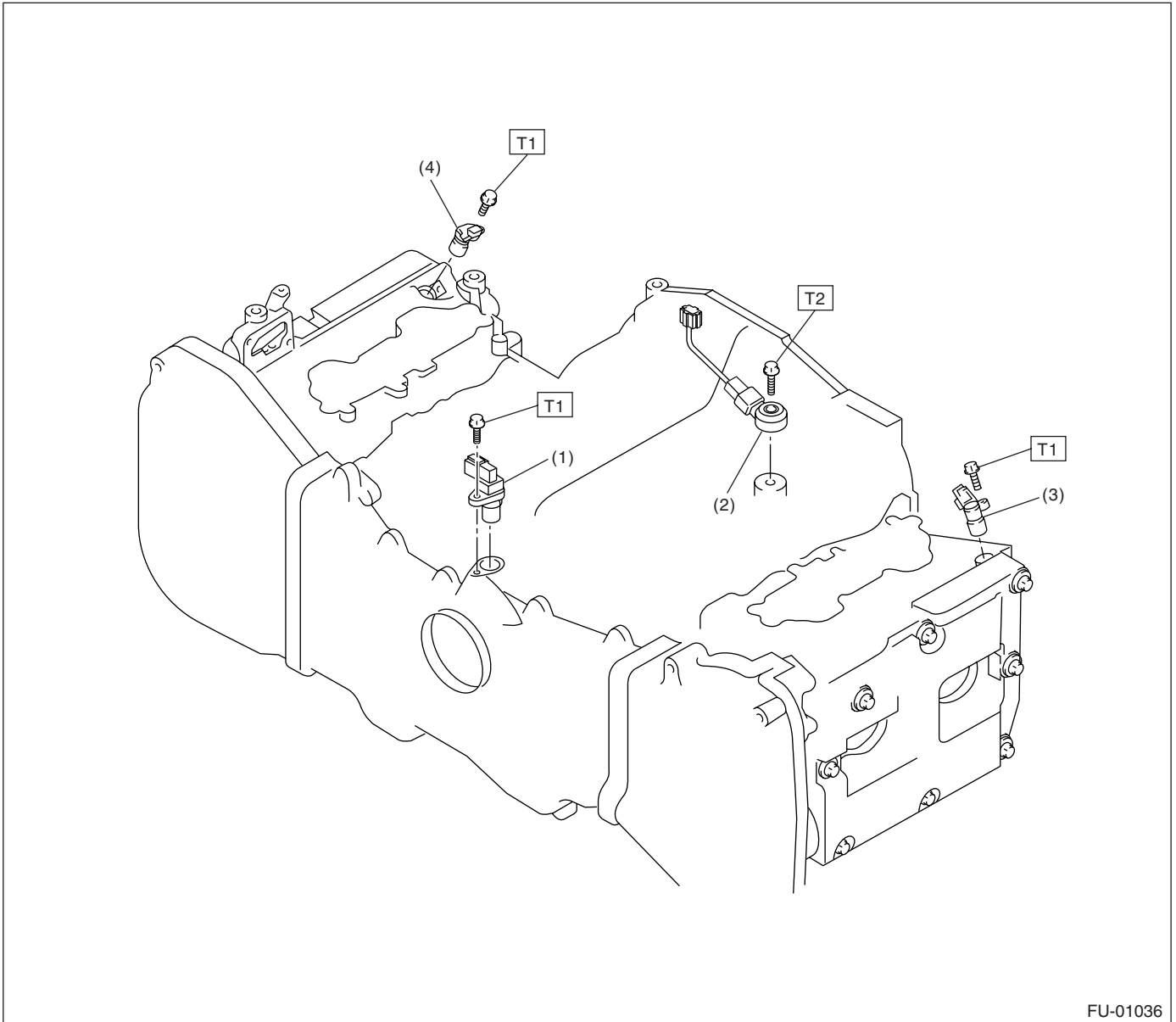

- (1) Crankshaft position sensor
- (2) Knock sensor

- (3) Camshaft position sensor LH
- (4) Camshaft position sensor RH

Tightening torque: N·m (kgf·m, ft·lb)

T1: 6.4 (0.65, 4.7)

T2: 24 (2.4, 17.4)

General Description

4. FUEL TANK

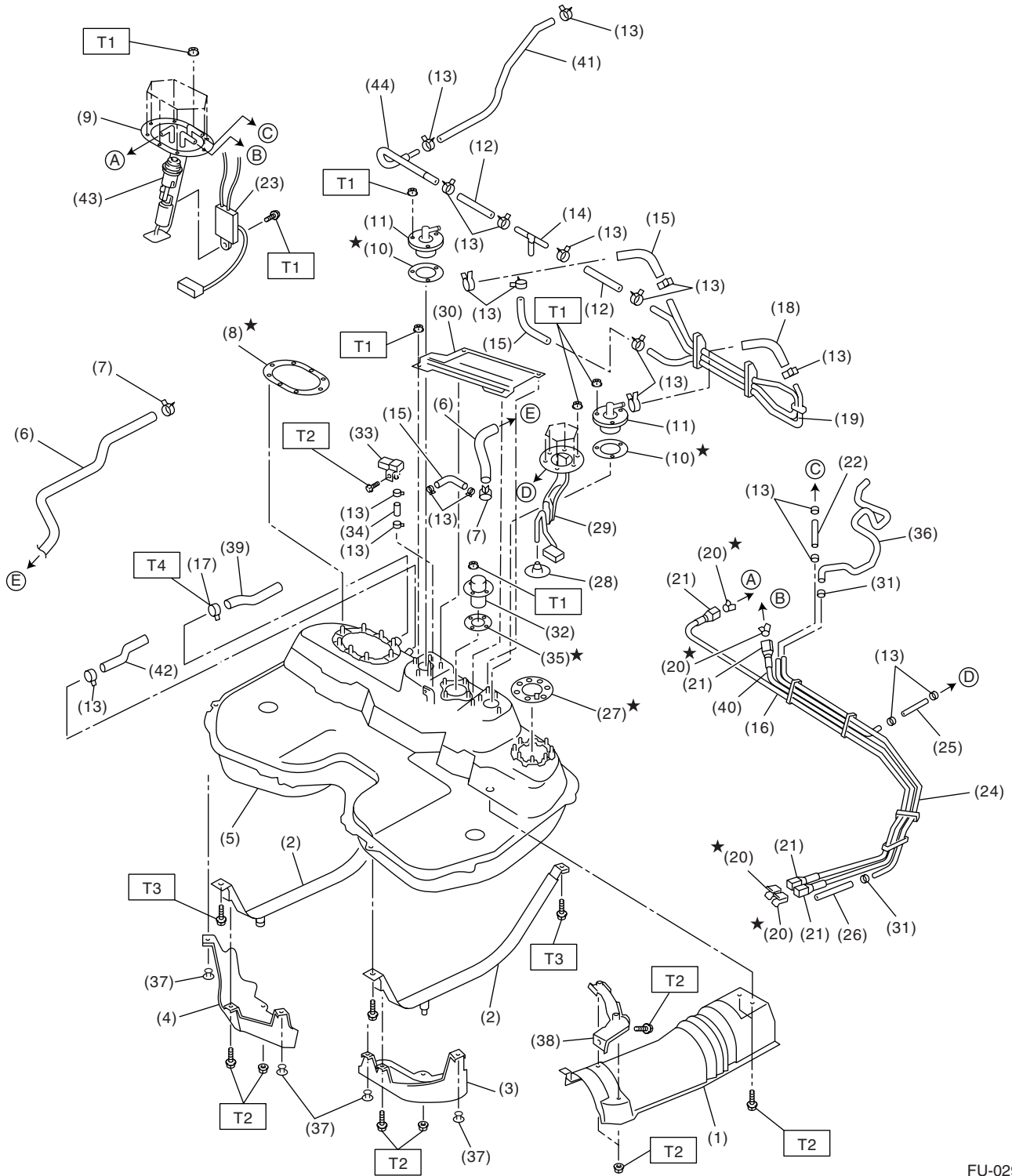

FU-02907

General Description

FUEL INJECTION (FUEL SYSTEMS)

(1) Heat shield cover	(18) Evaporation hose C	(35) Vent valve gasket
(2) Fuel tank band	(19) Evaporation pipe ASSY	(36) Purge hose
(3) Protector LH	(20) Retainer	(37) Clip
(4) Protector RH	(21) Quick connector	(38) Cover bracket
(5) Fuel tank	(22) Jet pump hose A	(39) Fuel filler hose
(6) Canister hose A	(23) Fuel level sensor	(40) Fuel return tube
(7) Clamp	(24) Fuel pipe ASSY	(41) Evaporation hose E
(8) Fuel pump gasket	(25) Jet pump hose B	(42) Evaporation hose F
(9) Fuel pump ASSY	(26) Evaporation hose D	(43) Fuel filter
(10) Fuel cut valve gasket	(27) Fuel sub level sensor gasket	(44) Evaporation pipe
(11) Fuel cut valve	(28) Jet pump filter	
(12) Evaporation hose A	(29) Fuel sub level sensor	
(13) Clip	(30) Protect cover	
(14) Joint pipe	(31) Clip	
(15) Evaporation hose B	(32) Vent valve	
(16) Fuel delivery tube	(33) Fuel tank pressure sensor	
(17) Clamp	(34) Fuel tank pressure sensor hose	

Tightening torque: N·m (kgf-m, ft-lb)

T1: 4.4 (0.45, 3.3)

T2: 7.4 (0.75, 5.4)

T3: 33 (3.4, 25)

T4: 1.96 (0.20, 1.45)

5. FUEL LINE

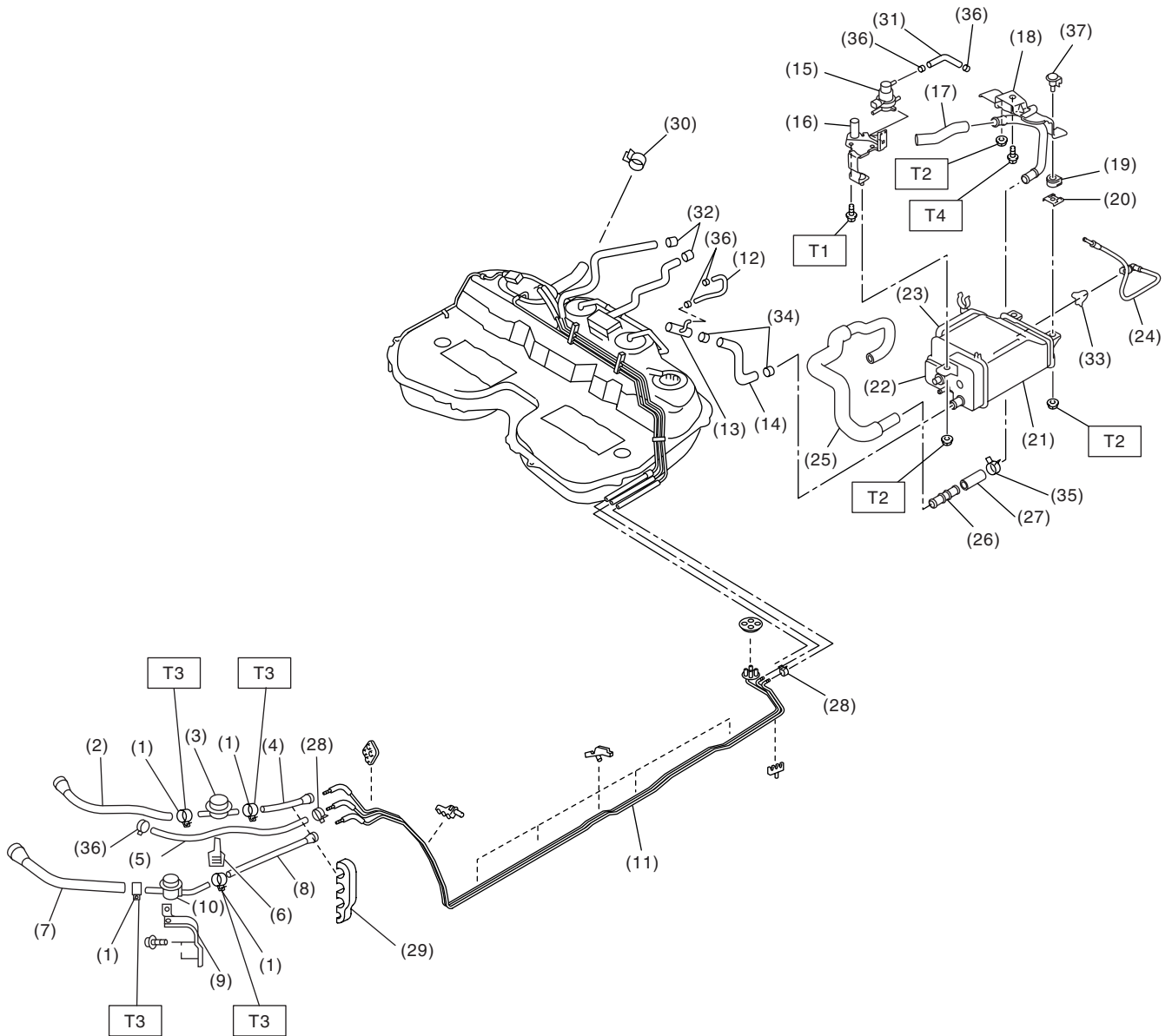

FU-02888

General Description

FUEL INJECTION (FUEL SYSTEMS)

(1) Clamp	(17) Drain hose C	(32) Clamp
(2) Fuel return hose A	(18) Canister upper bracket	(33) Retainer
(3) Fuel damper valve (return)	(19) Cushion rubber	(34) Clamp
(4) Fuel return hose B	(20) Canister lower bracket	(35) Clamp
(5) Evaporation hose A	(21) Canister	(36) Clamp
(6) Clip	(22) Drain valve	(37) Canister bracket spacer
(7) Fuel delivery hose A	(23) Drain filter	
(8) Fuel delivery hose B	(24) Pressure control solenoid valve tube	<hr/> Tightening torque: N-m (kgf-m, ft-lb)
(9) Fuel damper valve bracket	(25) Drain hose A	T1: 25 (2.5, 18.1)
(10) Fuel damper valve (delivery)	(26) Connector drain	T2: 23 (2.3, 16.6)
(11) Fuel pipe ASSY	(27) Drain hose B	T3: 1.25 (0.13, 0.94)
(12) Evaporation hose B	(28) Clamp	T4: 33 (3.4, 25)
(13) Joint pipe	(29) Clip	<hr/>
(14) Canister hose A	(30) Clamp	
(15) Pressure control solenoid valve	(31) Pressure control solenoid valve hose	
(16) Pressure control solenoid valve bracket		

6. FUEL FILLER PIPE

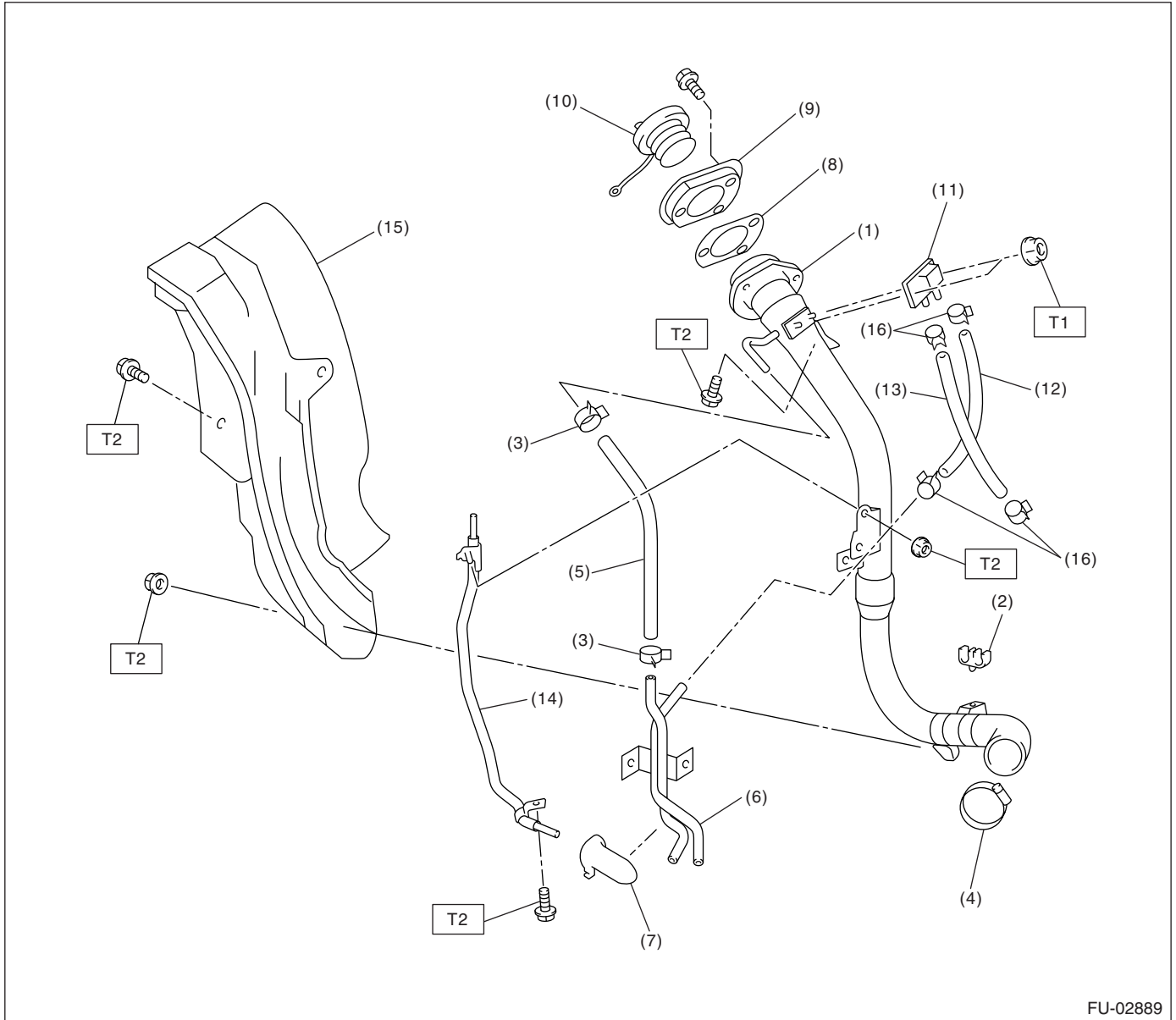

FU-02889

- | | | |
|-----------------------------|-------------------------|---------------------------------|
| (1) Fuel filler pipe ASSY | (8) Filler pipe packing | (15) Fuel filler pipe protector |
| (2) Evaporation hose holder | (9) Filler ring | (16) Clamp |
| (3) Clip | (10) Filler cap | |
| (4) Clamp | (11) Shut valve | |
| (5) Evaporation hose A | (12) Evaporation hose B | |
| (6) Evaporation pipe | (13) Evaporation hose C | |
| (7) Evaporation pipe holder | (14) Joint pipe | |

Tightening torque: N·m (kgf·m, ft·lb)

T1: 4.4 (0.45, 3.3)

T2: 7.5 (0.76, 5.5)

General Description

FUEL INJECTION (FUEL SYSTEMS)

C: CAUTION

- Wear work clothing, including a cap, protective goggles and protective shoes during operation.
- Remove contamination including dirt and corrosion before removal, installation or disassembly.
- Keep the disassembled parts in order and protect them from dust and dirt.
- Before removal, installation or disassembly, be sure to clarify the failure. Avoid unnecessary removal, installation, disassembly, and replacement.

- Be careful not to burn yourself, because each part on the vehicle is hot after running.
- Be sure to tighten fasteners including bolts and nuts to the specified torque.
- Place shop jacks or rigid racks at the specified points.
- Before disconnecting electrical connectors of sensors or units, be sure to disconnect the ground cable from battery.
- Place "NO FIRE" signs near the working area.
- Be careful not to spill fuel on the floor.

D: PREPARATION TOOL

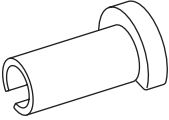
ILLUSTRATION	TOOL NUMBER	DESCRIPTION	REMARKS
 ST42099AE000	42099AE000	CONNECTOR REMOVER	Used for removing quick connector in engine compartment.

2. Throttle Body

A: REMOVAL

- 1) Disconnect the ground cable from battery.
- 2) Remove the intercooler. <Ref. to IN(H4DOTC)-11, REMOVAL, Intercooler.>
- 3) Disconnect the connector from the throttle position sensor (A) and manifold absolute pressure sensor (B).

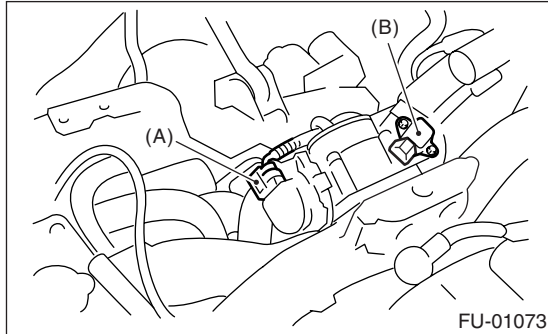

- 4) Disconnect the engine coolant hoses from the throttle body.

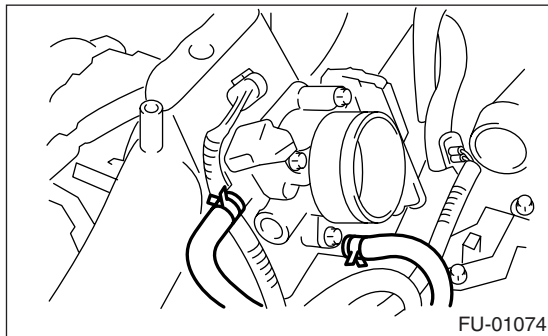

- 5) Remove the bolts which secure the throttle body to intake manifold.

B: INSTALLATION

- 1) Install in the reverse order of removal.

NOTE:

Always use a new gasket.

Tightening torque:

8 N·m (0.8 kgf-m, 5.8 ft-lb)

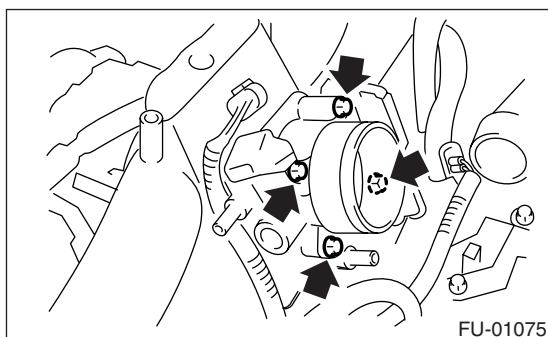

Intake Manifold

FUEL INJECTION (FUEL SYSTEMS)

3. Intake Manifold

A: REMOVAL

- 1) Release the fuel pressure. <Ref. to FU(H4DOTC)-50, RELEASING OF FUEL PRESSURE, PROCEDURE, Fuel.>
- 2) Disconnect the ground cable from battery.
- 3) Open the fuel filler flap lid and remove the fuel filler cap.
- 4) Lift up the vehicle.
- 5) Remove the under cover.
- 6) Drain the engine coolant about 3.0 ℓ (3.2 US qt, 2.6 Imp qt).

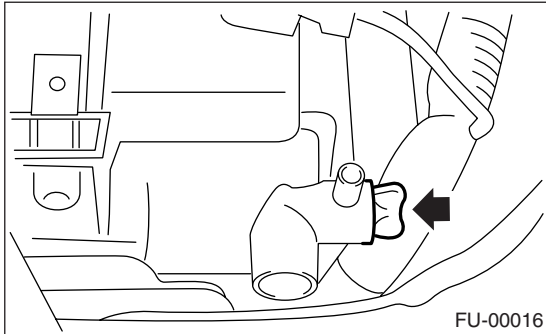

- 7) Remove the air cleaner upper cover and air intake boot. <Ref. to IN(H4DOTC)-8, REMOVAL, Air Cleaner Case.>
- 8) Remove the air cleaner element.
- 9) Remove the intercooler. <Ref. to IN(H4DOTC)-11, REMOVAL, Intercooler.>
- 10) Remove the coolant filler tank. <Ref. to CO(H4DOTC)-33, REMOVAL, Coolant Filler Tank.>
- 11) Remove the power steering pump.
 - (1) Remove the front side V-belt. <Ref. to ME(H4DOTC)-41, REMOVAL, V-belt.>
 - (2) Disconnect the power steering switch connector.

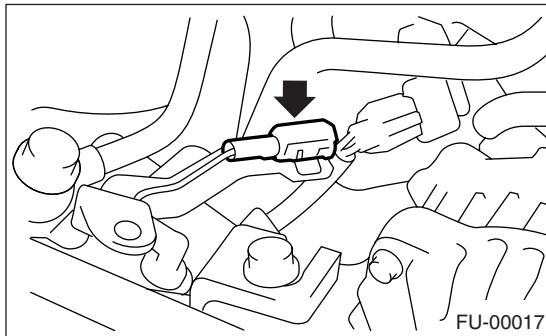

- (3) Remove the bolts which secure the power steering pipe brackets to the intake manifold.

NOTE:

Do not disconnect the power steering hose.

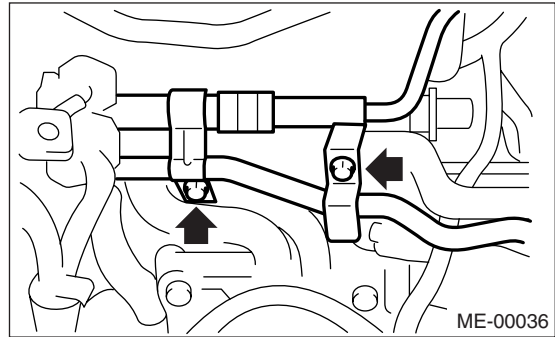

- (4) Remove the bolts which secure the power steering pump bracket.

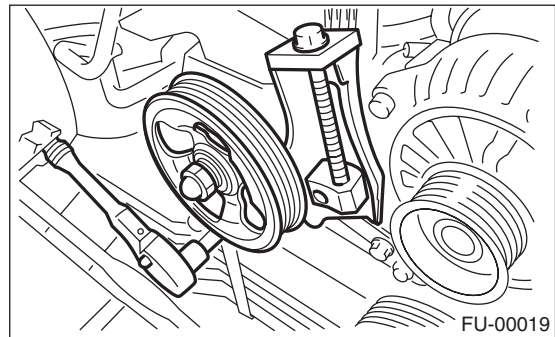

- (5) Remove the power steering tank from the bracket by pulling it upward.

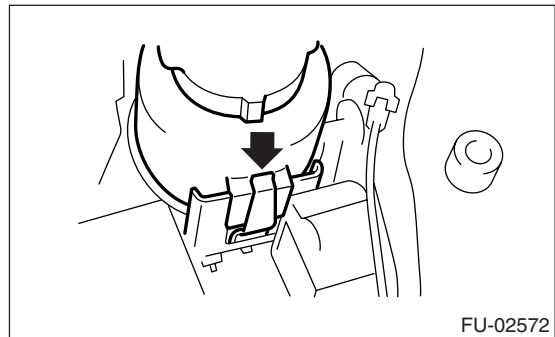

- (6) Place the power steering pump on the right side wheel apron.

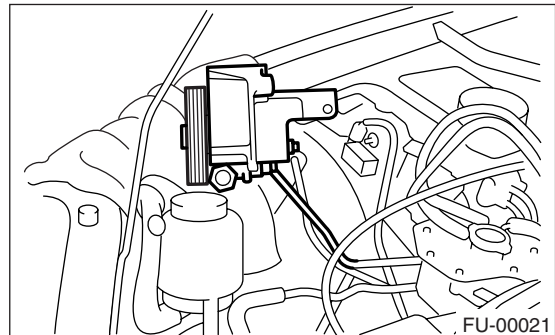

Intake Manifold

FUEL INJECTION (FUEL SYSTEMS)

12) Disconnect the emission hose (A) and connector (B) from the PCV hose assembly.

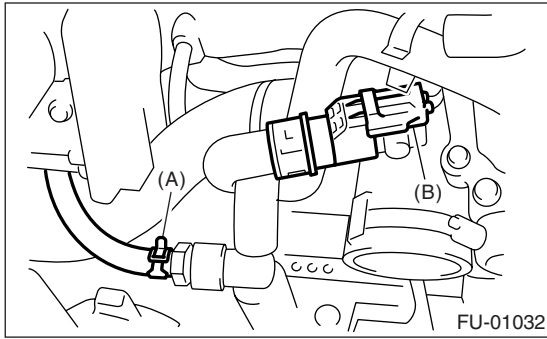

16) Disconnect the engine harness connectors from the bulkhead harness connectors.

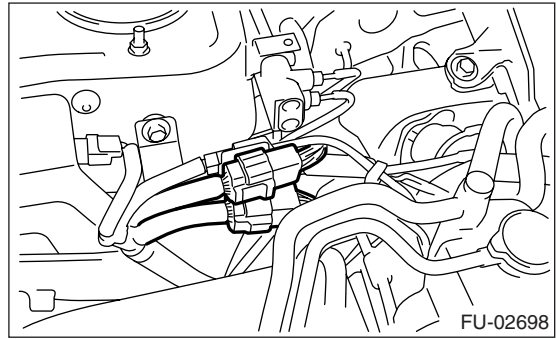

13) Disconnect the engine coolant hoses from the throttle body.

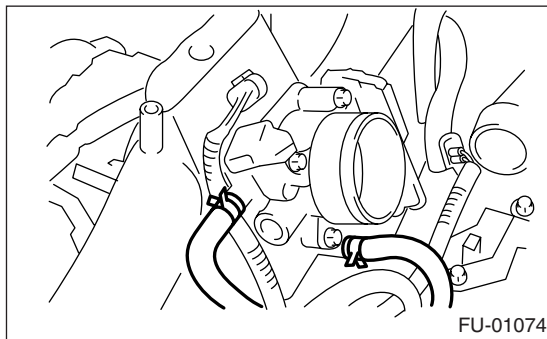

17) Remove the engine harness connector from front harness connector.

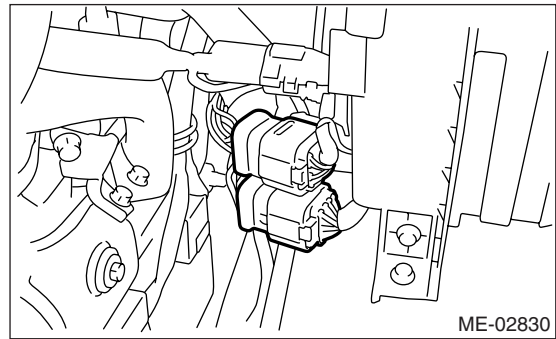

14) Disconnect the brake booster vacuum hose.

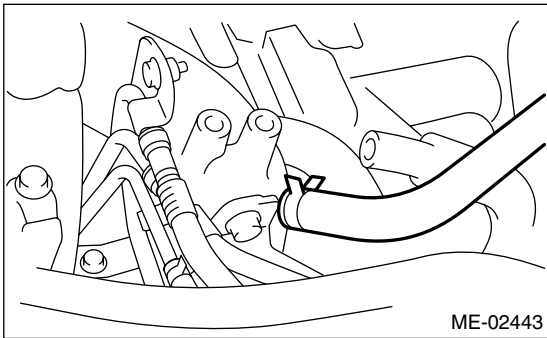

18) Disconnect the connectors from the engine coolant temperature sensor (A), oil pressure switch (B) and crankshaft position sensor (C).

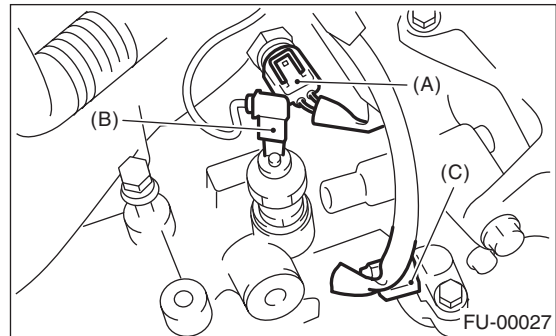

15) Disconnect the pressure hose from the intake duct.

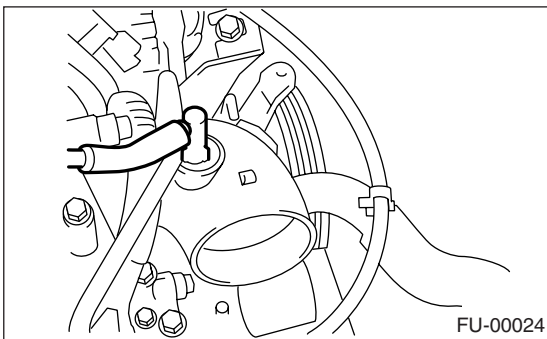

19) Disconnect the knock sensor connector.

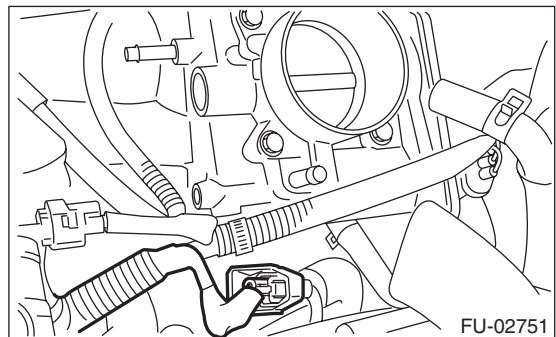

Intake Manifold

FUEL INJECTION (FUEL SYSTEMS)

20) Disconnect the connector from the camshaft position sensor.

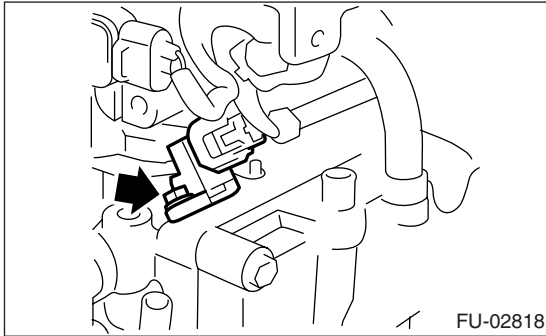

21) Disconnect the connector from the ignition coil and ignitor assembly.

- RH side

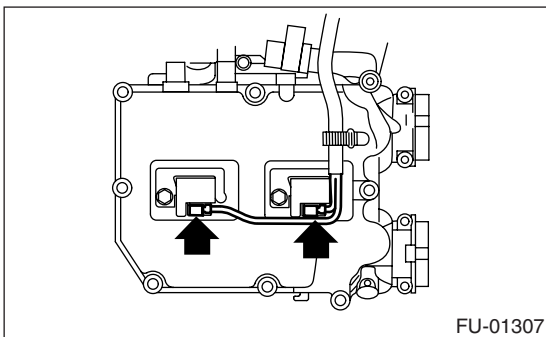

- LH side

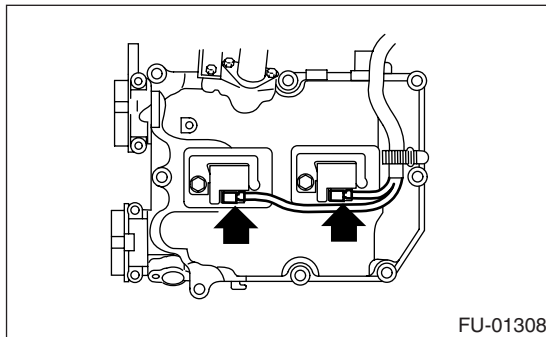

22) Disconnect the engine harness fixed by clip (A) from the rocker cover.

- RH side

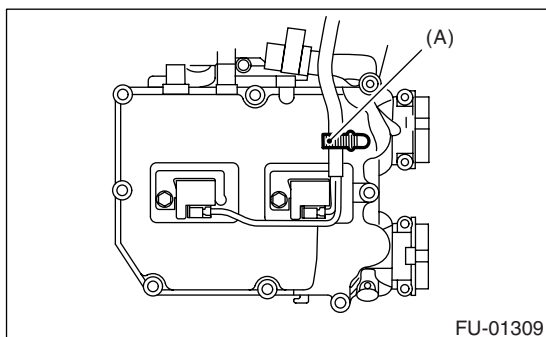

- LH side

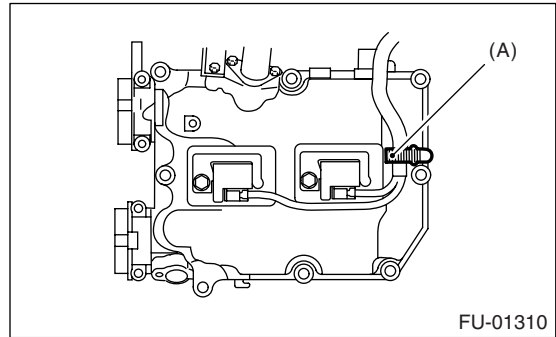

23) Using ST, disconnect fuel hoses from fuel pipes. <Ref. to FU(H4DOTC)-65, REMOVAL, Fuel Delivery, Return and Evaporation lines.>

CAUTION:

- Be careful not to spill fuel.
- Catch fuel from hoses using a container or cloth.

ST 42099AE000 CONNECTOR REMOVER

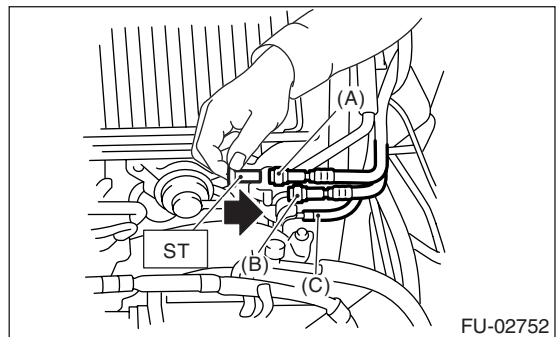

- (A) Fuel delivery hose
- (B) Return hose
- (C) Evaporation hose

24) Remove the bolts which secure the intake manifold to the cylinder heads.

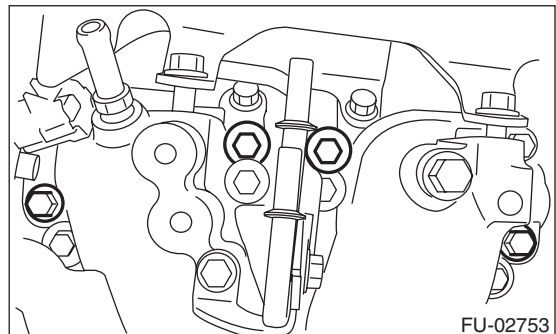

25) Remove the intake manifold.

B: INSTALLATION

1) Install the intake manifold onto cylinder heads.

NOTE:

Always use new gaskets.

Tightening torque:

25 N·m (2.5 kgf-m, 18.1 ft-lb)

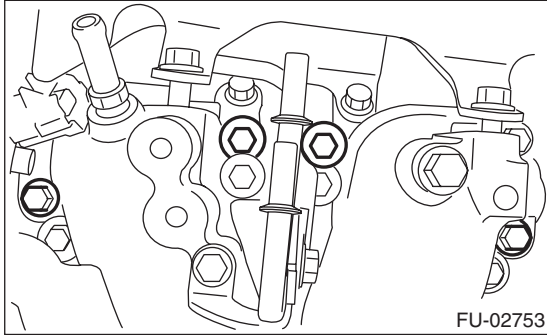

2) Connect the fuel delivery hose, return hose and evaporation hose.

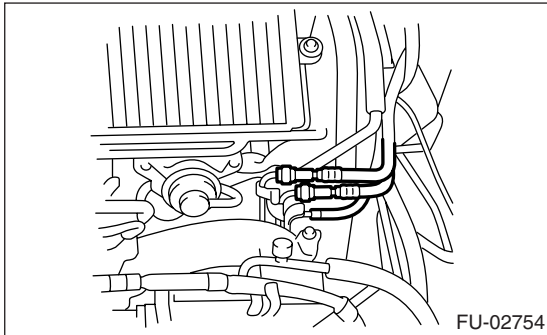

3) Connect the connector to the oil pressure switch (B), crankshaft position sensor (A) and engine coolant temperature sensor (A).

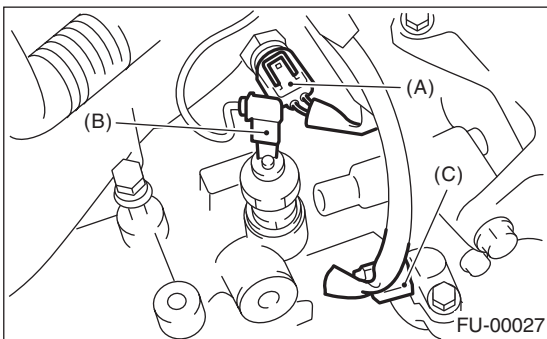

4) Connect the connector to the knock sensor.

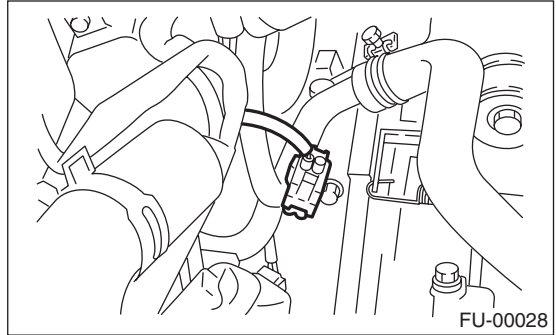

5) Connect the connector to the camshaft position sensor.

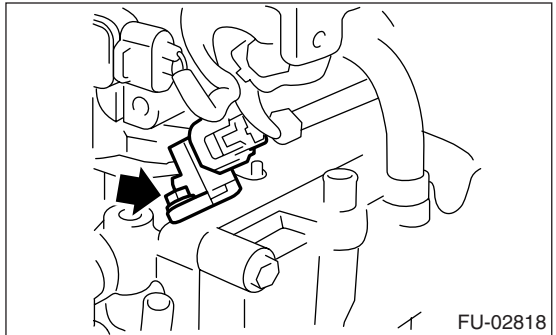

6) Connect the connector to the ignition coil and ignitor assembly.

- RH side

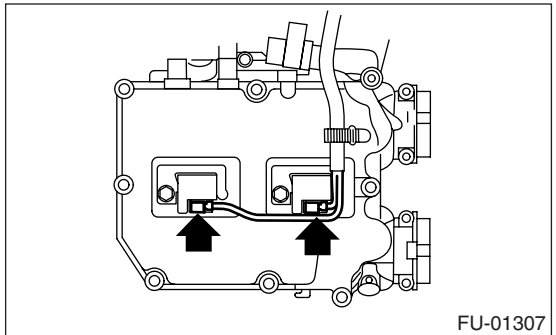

- LH side

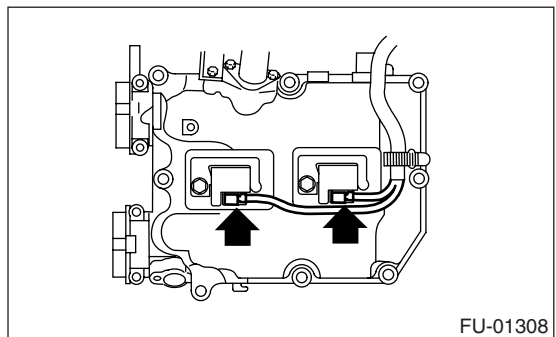

Intake Manifold

FUEL INJECTION (FUEL SYSTEMS)

7) Connect the engine harness with clip (A) to the rocker cover.

- RH side

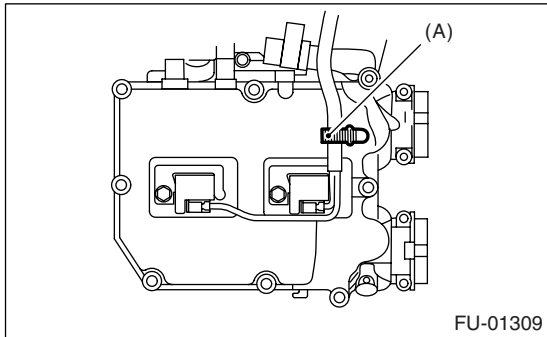

- LH side

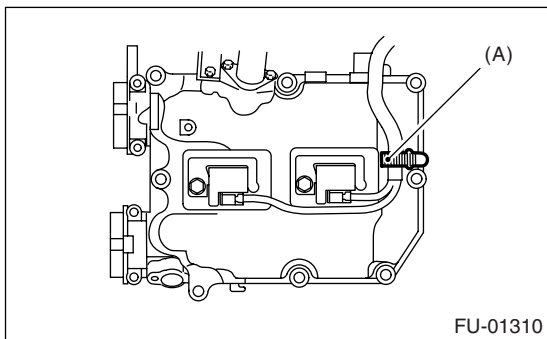

8) Connect the engine harness connector to front harness connector.

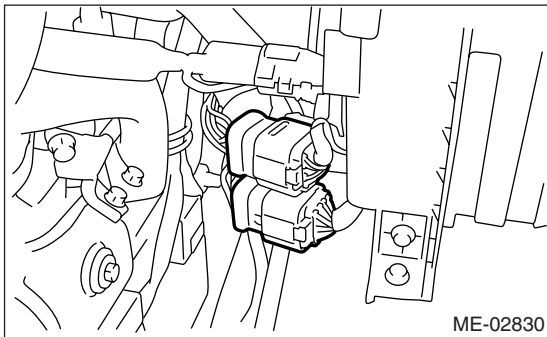

9) Connect the engine harness connector to the bulkhead harness connectors.

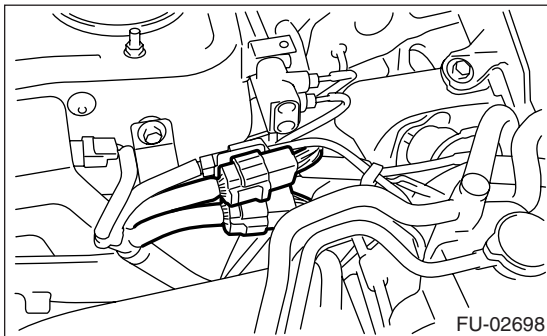

10) Connect the brake booster vacuum hose.

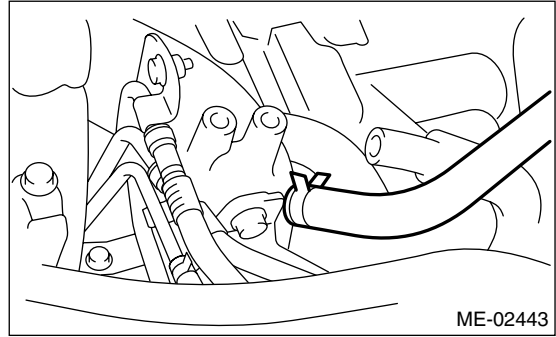

11) Connect the engine coolant hoses to the throttle body.

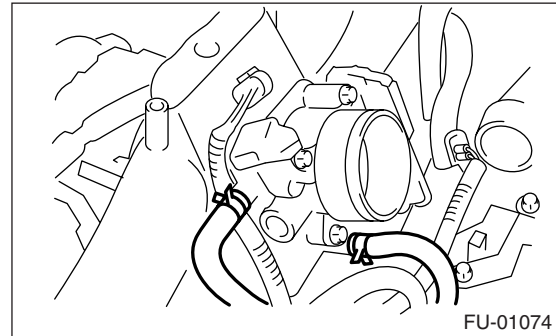

12) Connect the emission hose (A) and connector (B) to the PCV hose assembly.

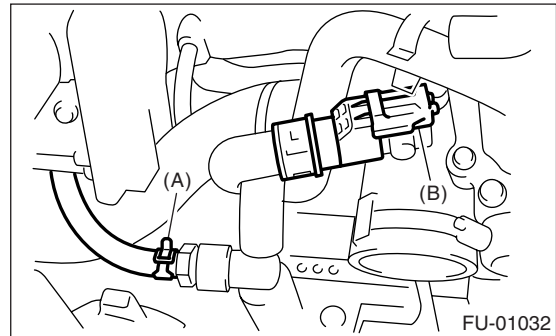

13) Connect the pressure hose to the intake duct.

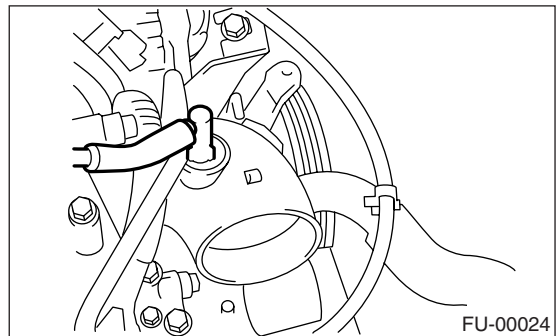

Intake Manifold

FUEL INJECTION (FUEL SYSTEMS)

14) Install the power steering pump.

(1) Install the power steering tank on the bracket.

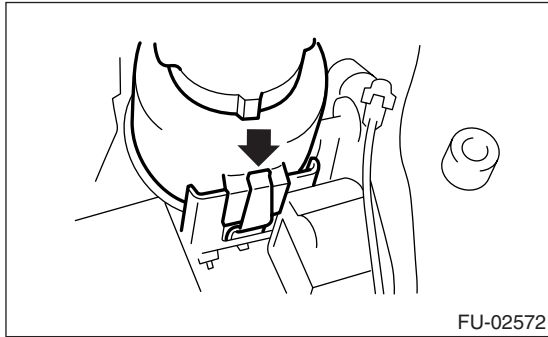

(2) Connect the connector to the power steering pump switch.

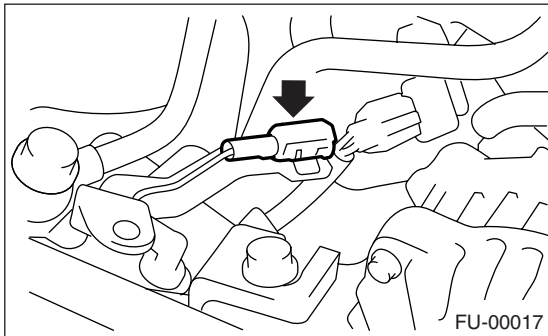

(3) Install the power steering pump, and tighten the bolts.

Tightening torque:

22 N·m (2.2 kgf·m, 15.9 ft·lb)

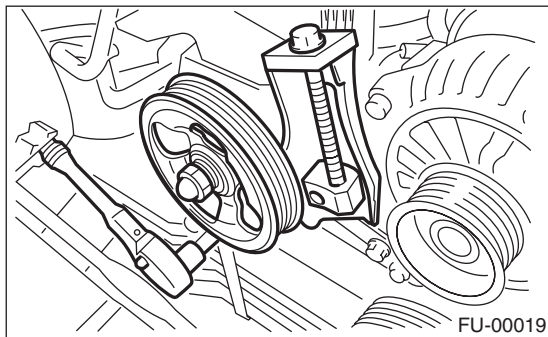

(4) Install the power steering pipe brackets on the intake manifold RH.

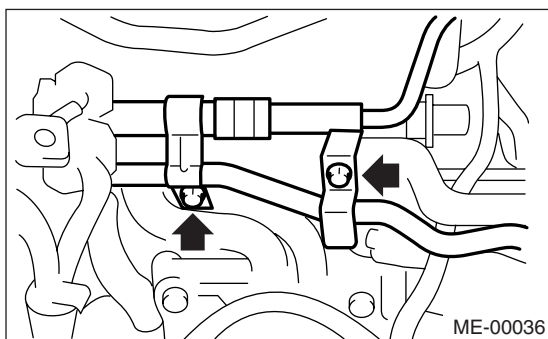

(5) Install the front side V-belt. <Ref. to ME(H4DOTC)-41, REMOVAL, V-belt.>

15) Install the coolant filler tank. <Ref. to CO(H4DOTC)-33, INSTALLATION, Coolant Filler Tank.>

16) Install the intercooler. <Ref. to IN(H4DOTC)-11, INSTALLATION, Intercooler.>

17) Install the air cleaner element.

18) Install the air cleaner upper cover and air intake duct as a unit. <Ref. to IN(H4DOTC)-8, INSTALLATION, Air Cleaner Case.>

19) Connect the connector to the fuel pump relay.

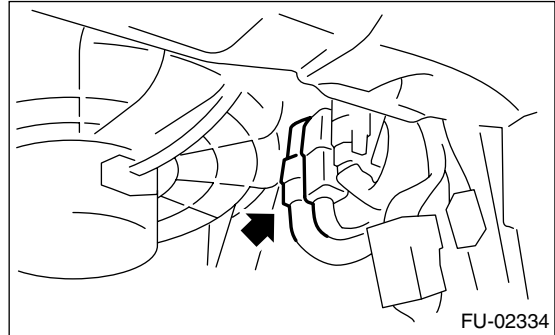

20) Connect the battery ground cable to battery.

21) Lift up the vehicle.

22) Install the under cover.

23) Fill the engine coolant. <Ref. to CO(H4DOTC)-17, FILLING OF ENGINE COOLANT, REPLACEMENT, Engine Coolant.>

C: DISASSEMBLY

1) Remove the fuel pipe protector RH.

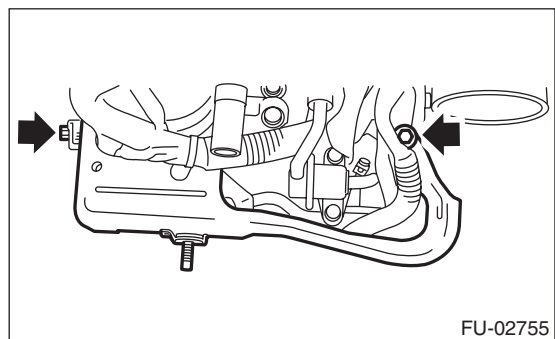

2) Remove the fuel pipe protector LH.

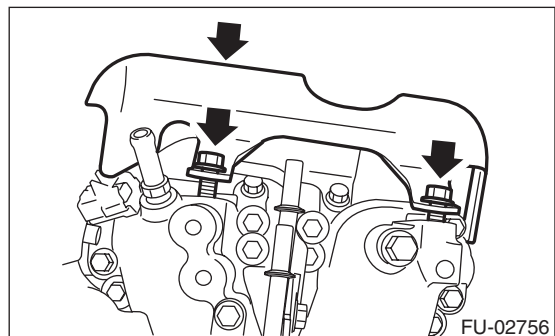

Intake Manifold

FUEL INJECTION (FUEL SYSTEMS)

3) Remove the engine ground terminal from the intake manifold.

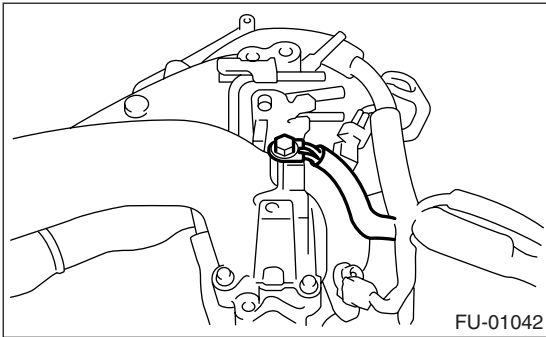
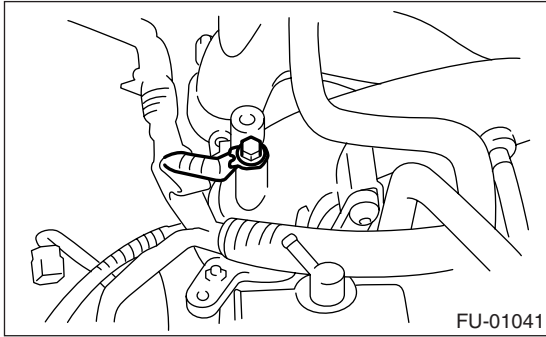

4) Disconnect the connector from the throttle position sensor (A) and manifold absolute pressure sensor (B).

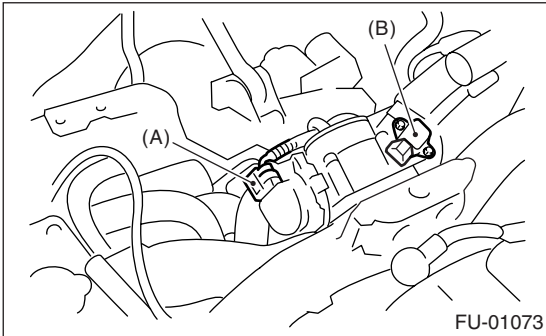

5) Remove the throttle body from the intake manifold.

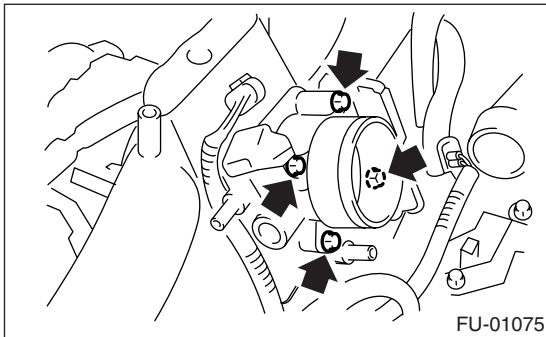

6) Disconnect the connector from the fuel injector.

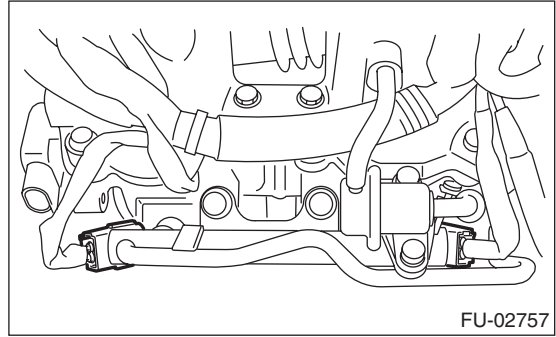

7) Disconnect the connector from the tumble generator valve actuator.

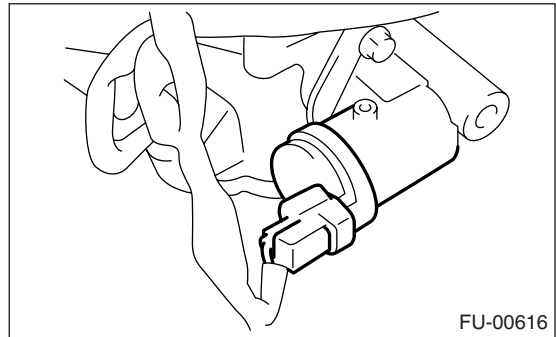

8) Disconnect the connector from the tumble generator valve sensor.

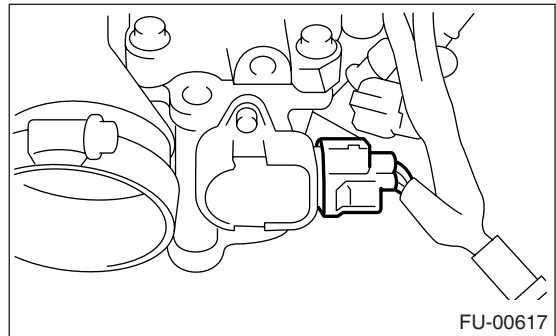

9) Disconnect the connector from the purge control solenoid valve.

10) Remove the purge control solenoid valve.

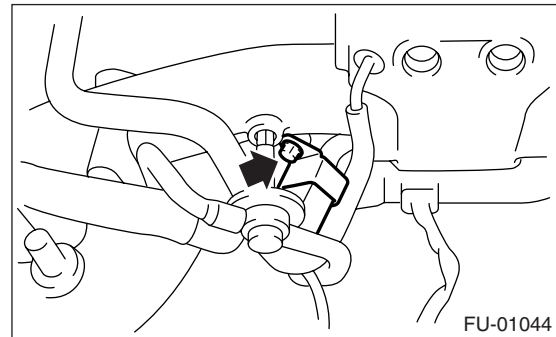

Intake Manifold

FUEL INJECTION (FUEL SYSTEMS)

11) Disconnect the evaporation hose and purge valve from the intake manifold.

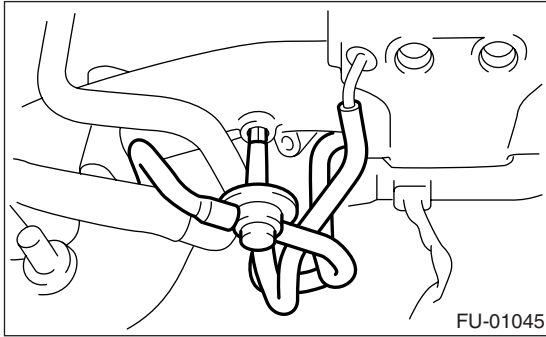

12) Remove the two bolts which hold the fuel pipes on the left side of intake manifold.

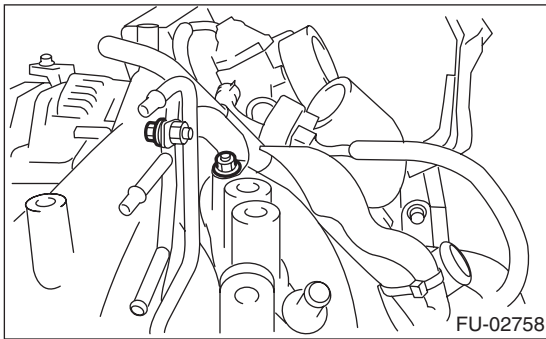

13) Remove the bolt which hold the fuel injector pipe onto intake manifold.

• LH side

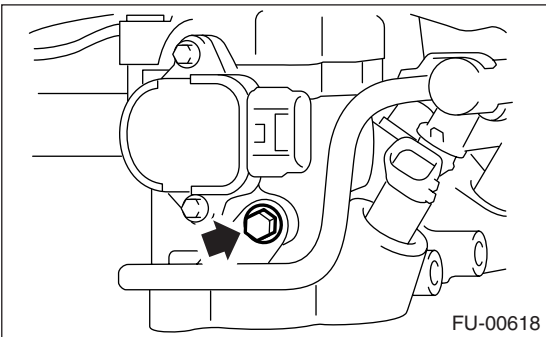
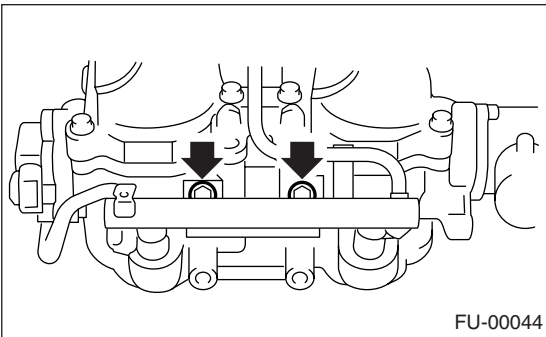

• RH side

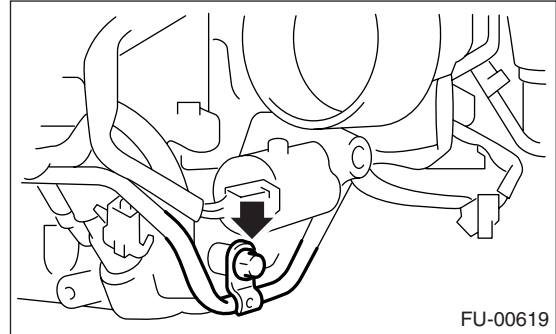
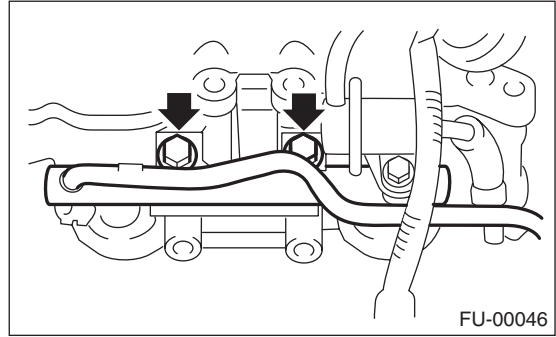

14) Remove the fuel injector.

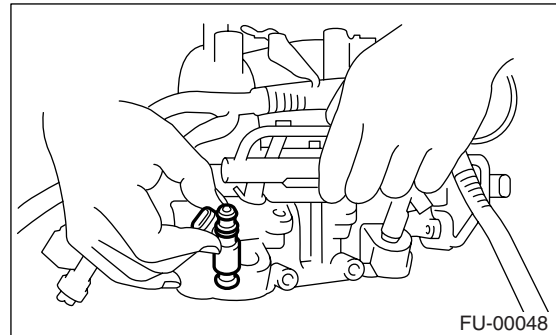

15) Remove the harness bracket which holds the engine harness onto intake manifold.

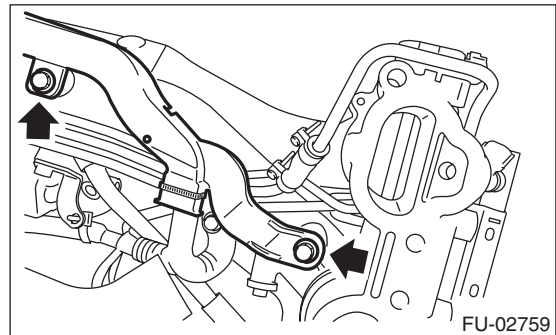

16) Remove the engine harness from the intake manifold.

Intake Manifold

FUEL INJECTION (FUEL SYSTEMS)

17) Loosen the clamp which holds the front left side fuel hose to fuel injector pipe and remove the pipe from clamp.

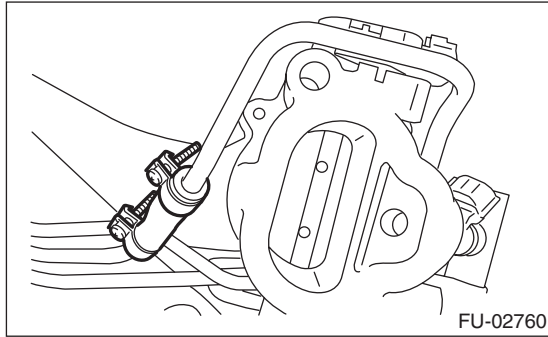

18) Loosen the clamp which hold RH side fuel hose to fuel injector pipe, and remove the fuel injector pipe from clamp.

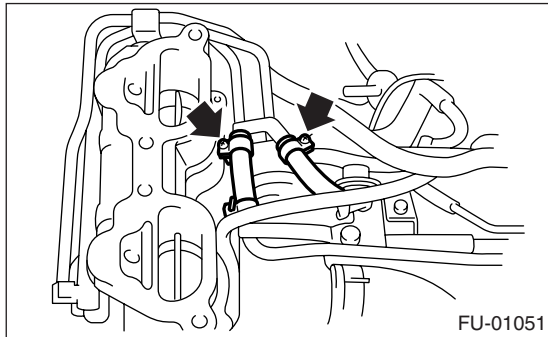

19) Remove the bolts which install the fuel pipe assembly on intake manifold.

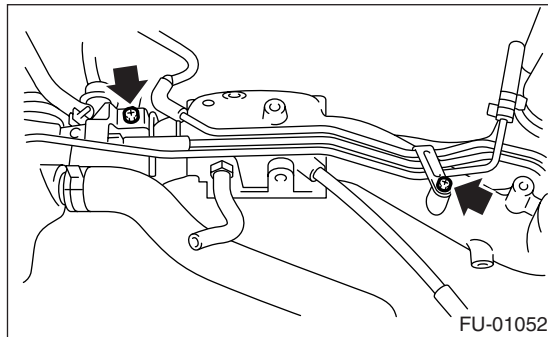

20) Remove the fuel pipe assembly and pressure regulator, from the intake manifold.

21) Remove the intake duct from the intake manifold.

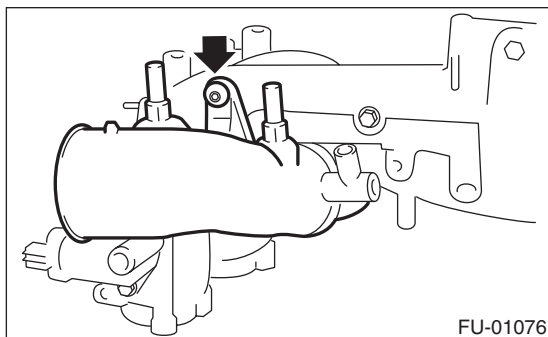

22) Remove the tumble generator valve assembly from the intake manifold.

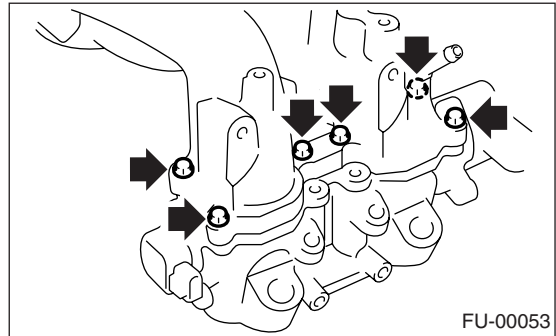

D: ASSEMBLY

NOTE:

Replace the gasket with a new one.

1) Install the tumble generator valve assembly to the intake manifold.

Tightening torque:

8.25 N·m (0.84 kgf-m, 6.1 ft-lb)

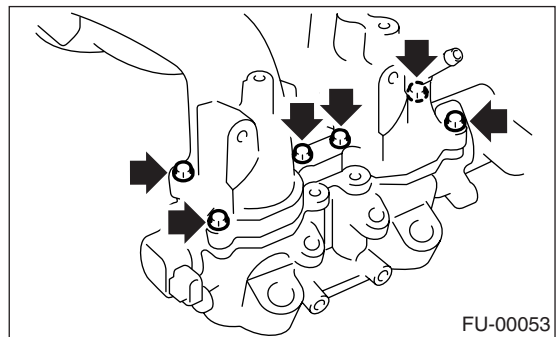

2) Install the air intake duct to the intake manifold.

Tightening torque:

19 N·m (1.94 kgf-m, 13.7 ft-lb)

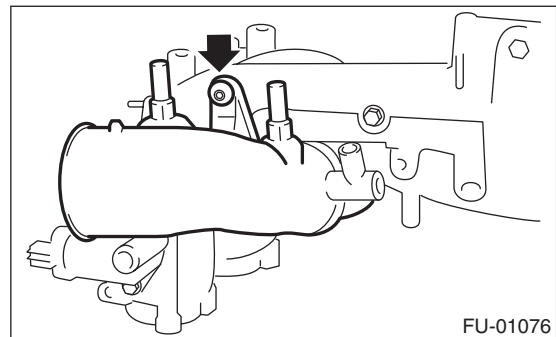

Intake Manifold

FUEL INJECTION (FUEL SYSTEMS)

3) Install the fuel pipe assembly and pressure regulator to the intake manifold.

Tightening torque:
6.4 N·m (0.65 kgf-m, 4.7 ft-lb)

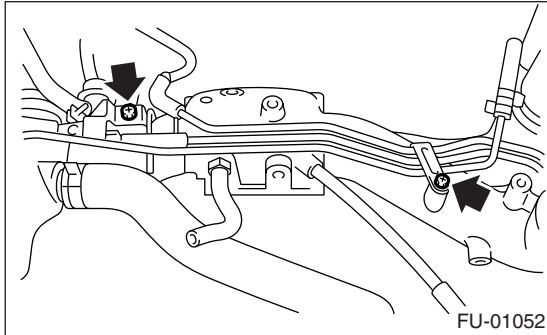

4) Install the fuel injector pipe LH.
5) Connect the left side fuel hose LH to fuel injector pipe, and tighten the clamp screw.

Tightening torque:
1.25 N·m (0.13 kgf-m, 0.94 ft-lb)

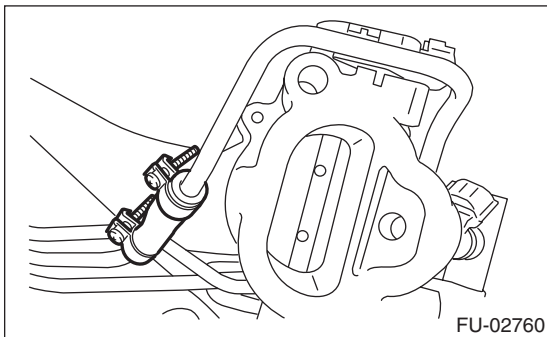

6) Install the fuel injector pipe RH.
7) Connect the fuel hose RH to fuel injector pipe, and tighten the clamp screw.

Tightening torque:
1.25 N·m (0.13 kgf-m, 0.94 ft-lb)

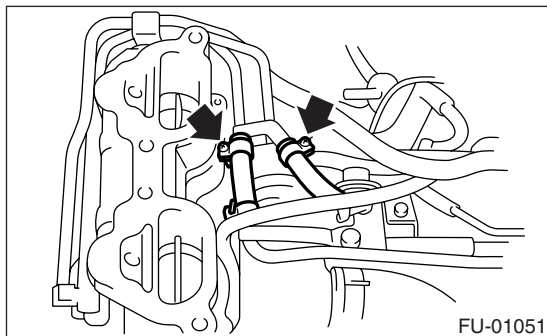

8) Install the engine harness to the intake manifold.
9) Install the harness bracket which holds the engine harness onto intake manifold.

Tightening torque:
19 N·m (1.94 kgf-m, 13.7 ft-lb)

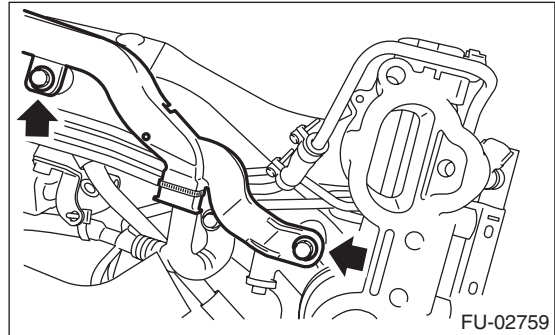

10) Install the fuel injector.

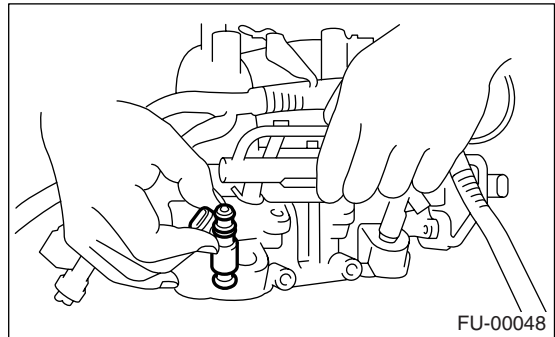

11) Tighten the bolts which install the fuel injector pipe onto intake manifold.

Tightening torque:
19 N·m (1.94 kgf-m, 13.7 ft-lb)

- LH side

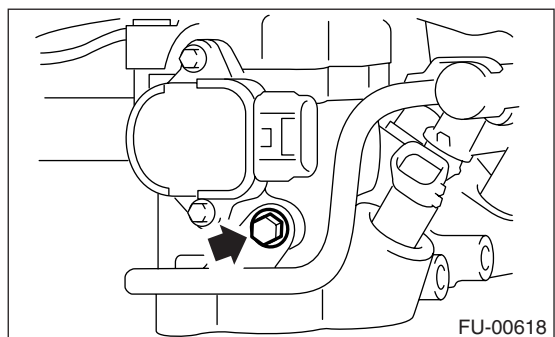
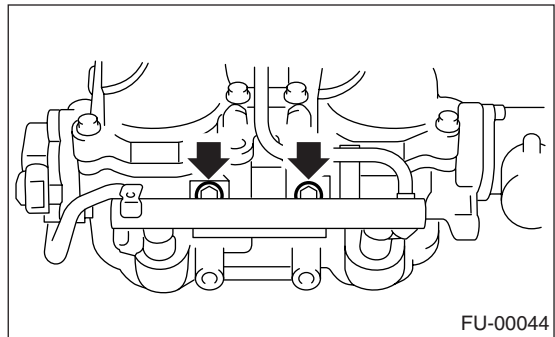

Intake Manifold

FUEL INJECTION (FUEL SYSTEMS)

- RH side

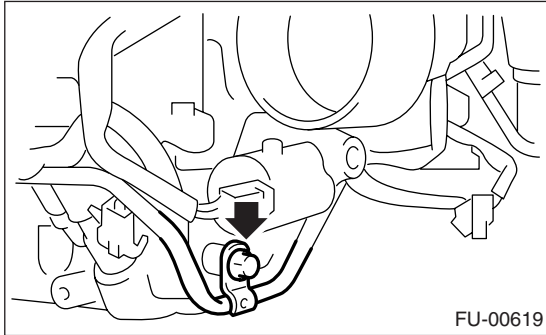
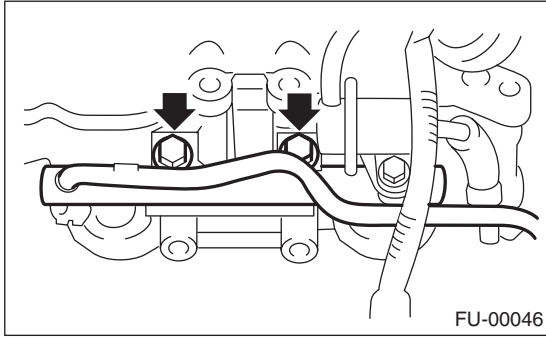

12) Tighten the two bolts which install the fuel injector pipes on the left side of intake manifold.

Tightening torque:

6.4 N·m (0.65 kgf-m, 4.7 ft-lb)

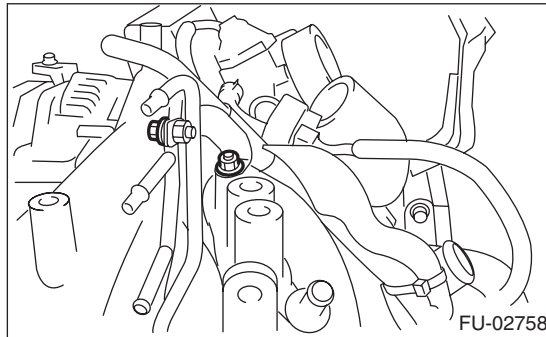

13) Connect the evaporation hoses to the purge valve.

NOTE:

Connect the evaporation hoses as shown in the figure.

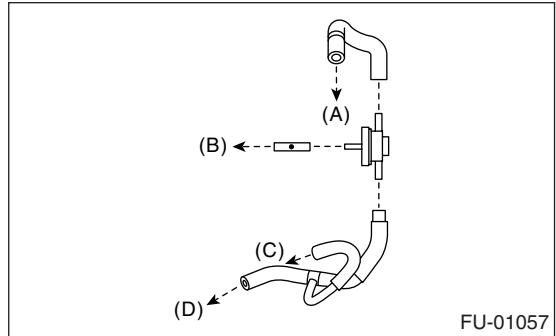

- (A) To intake duct
- (B) To intake manifold
- (C) To purge control solenoid valve
- (D) To fuel pipe ASSY

14) Connect the evaporation hose and purge valve to the intake manifold.

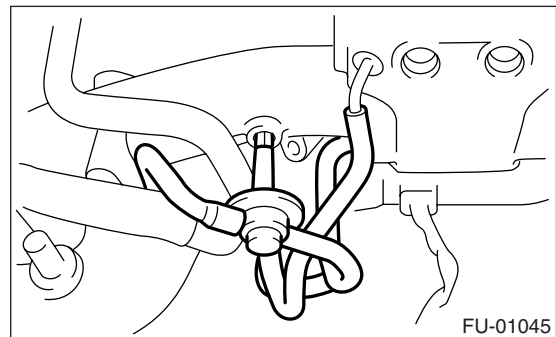

15) Install the purge control solenoid valve.

Tightening torque:

16 N·m (1.6 kgf-m, 11.6 ft-lb)

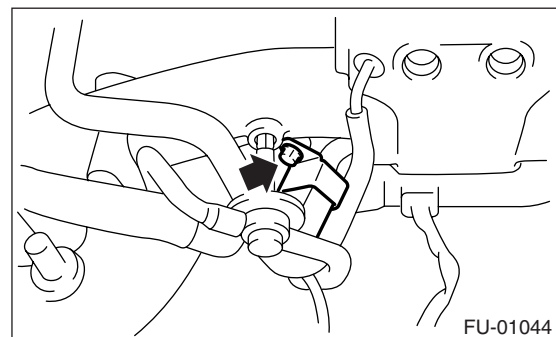

16) Connect the hoses to the purge control solenoid valve.

Intake Manifold

FUEL INJECTION (FUEL SYSTEMS)

NOTE:
Connect the evaporation hoses as shown in the figure.

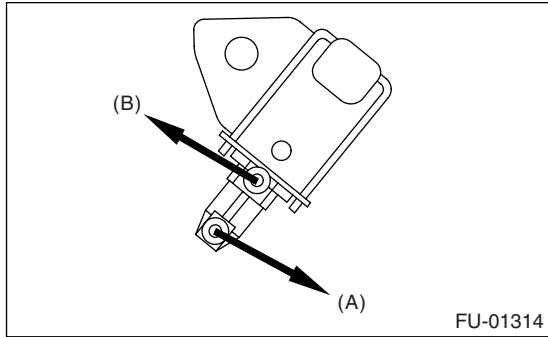

- (A) To purge valve
- (B) To intake manifold

17) Connect the connector to the purge control solenoid valve.

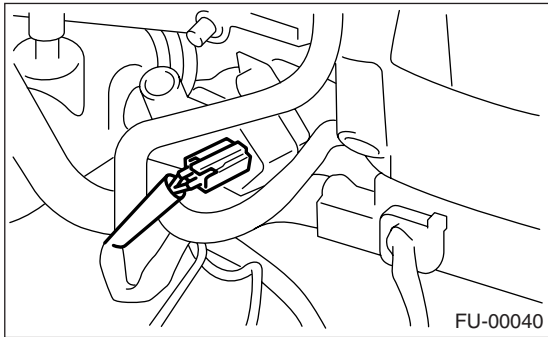

18) Connect the connector to the tumble generator valve sensor.

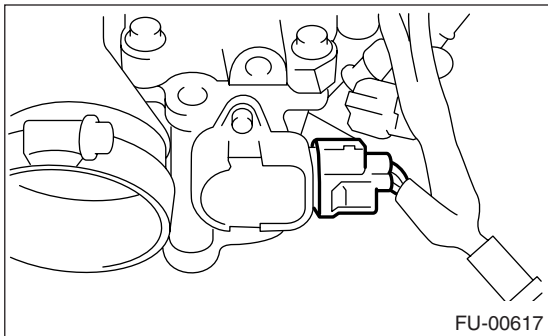

19) Connect the connector to the tumble generator valve actuator.

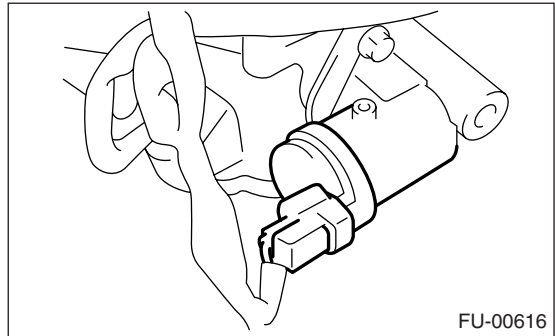

20) Connect the connector to the fuel injector.

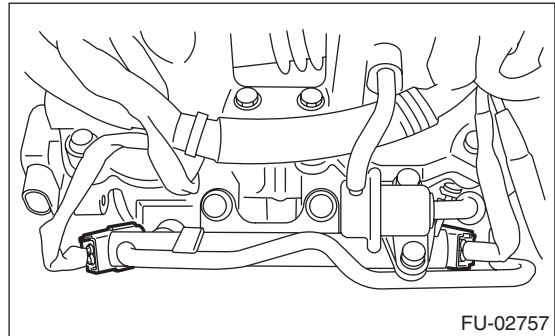

21) Install the throttle body to the intake manifold.

NOTE:
Replace the gasket with a new one.

Tightening torque:
8 N·m (0.8 kgf-m, 5.8 ft-lb)

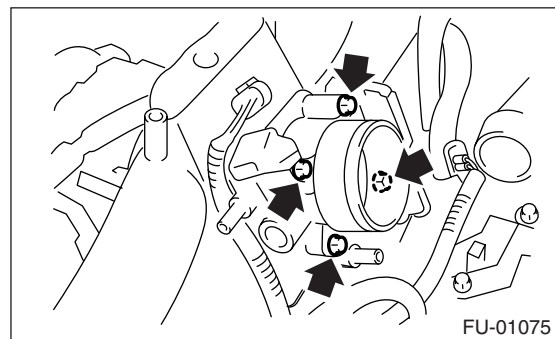

22) Connect the connector to the throttle position sensor (A) and manifold absolute pressure sensor (B).

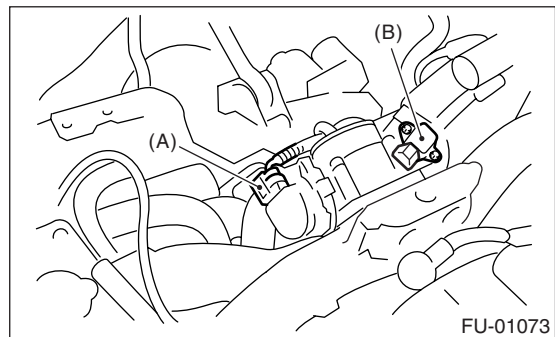

Intake Manifold

FUEL INJECTION (FUEL SYSTEMS)

23) Install the engine ground terminal to the intake manifold.

Tightening torque:

19 N·m (1.94 kgf-m, 13.7 ft-lb)

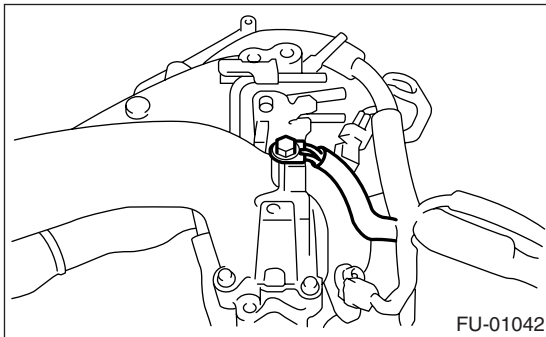
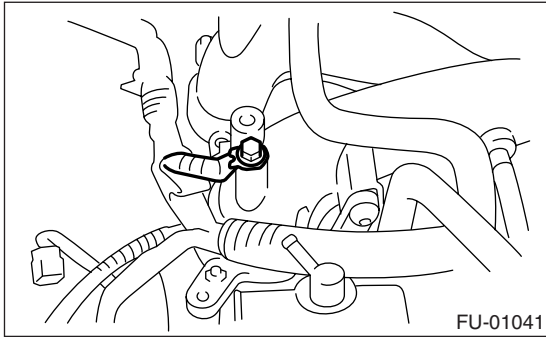

24) Install the fuel pipe protector RH.

Tightening torque:

19 N·m (1.94 kgf-m, 13.7 ft-lb)

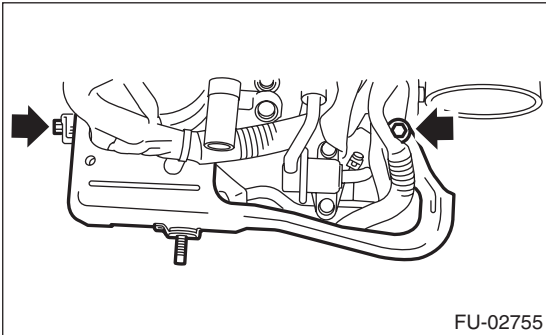

25) Install the fuel pipe protector LH.

Tightening torque:

19 N·m (1.94 kgf-m, 13.7 ft-lb)

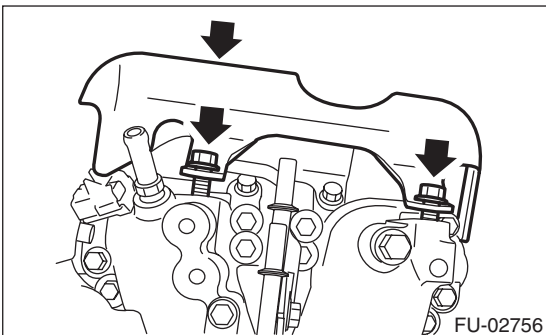

E: INSPECTION

Make sure the fuel pipe and fuel hoses are not cracked and the connections are tightened.

4. Engine Coolant Temperature Sensor

A: REMOVAL

- 1) Disconnect the ground cable from battery.
- 2) Remove the generator. <Ref. to SC(H4SO)-14, REMOVAL, Generator.>
- 3) Drain the engine coolant. <Ref. to CO(H4DOTC)-17, DRAINING OF ENGINE COOLANT, REPLACEMENT, Engine Coolant.>
- 4) Disconnect the connector from the engine coolant temperature sensor.

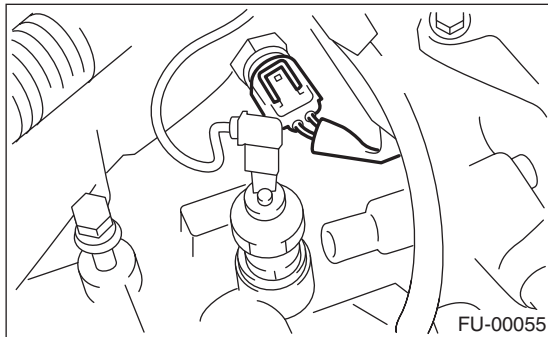

- 5) Remove the engine coolant temperature sensor.

B: INSTALLATION

Install in the reverse order of removal.

NOTE:

Use a new gasket.

Tightening torque:

18 N·m (1.8 kgf·m, 13.3 ft·lb)

Crankshaft Position Sensor

FUEL INJECTION (FUEL SYSTEMS)

5. Crankshaft Position Sensor

A: REMOVAL

- 1) Disconnect the ground cable from battery.
- 2) Remove the bolt which installs the crankshaft position sensor to cylinder block.

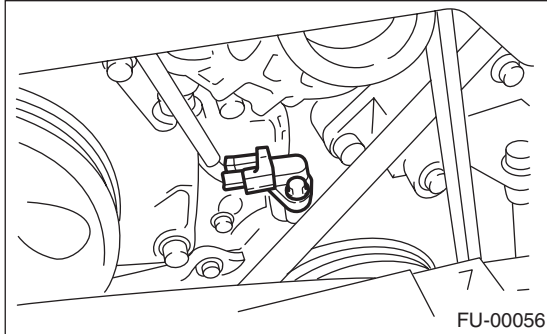

- 3) Remove the crankshaft position sensor, and disconnect the connector from it.

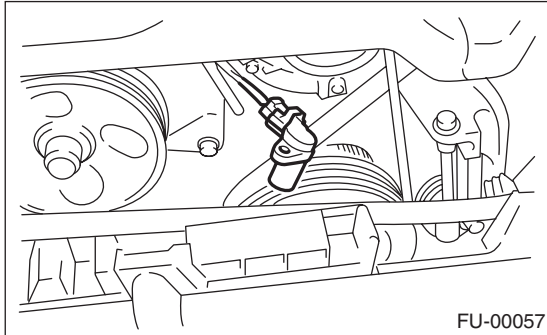

B: INSTALLATION

Install in the reverse order of removal.

Tightening torque:

T: 6.4 N·m (0.65 kgf-m, 4.7 ft-lb)

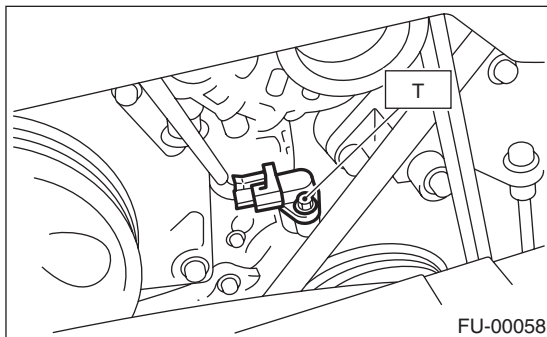

6. Camshaft Position Sensor

A: REMOVAL

- 1) Disconnect the ground cable from battery.
- 2) Disconnect the connector from the camshaft position sensor RH.
- 3) Remove the camshaft position sensor RH from the rear side of cylinder head.

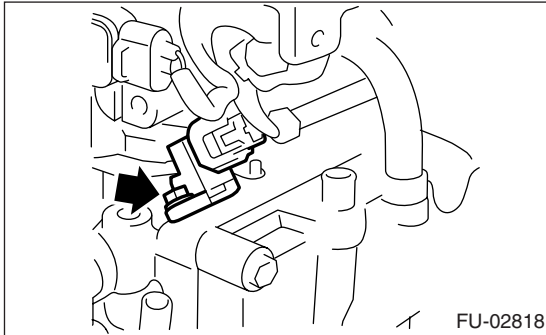

- 4) Remove the camshaft position sensor LH in the same procedure as RH side.

B: INSTALLATION

Install in the reverse order of removal.

Tightening torque:

6.4 N·m (0.65 kgf-m, 4.7 ft-lb)

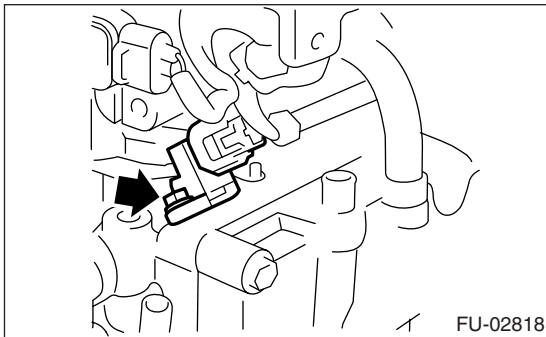

Knock Sensor

FUEL INJECTION (FUEL SYSTEMS)

7. Knock Sensor

A: REMOVAL

- 1) Disconnect the ground cable from battery.
- 2) Remove the intercooler. <Ref. to IN(H4DOTC)-11, REMOVAL, Intercooler.>
- 3) Disconnect the knock sensor connector.

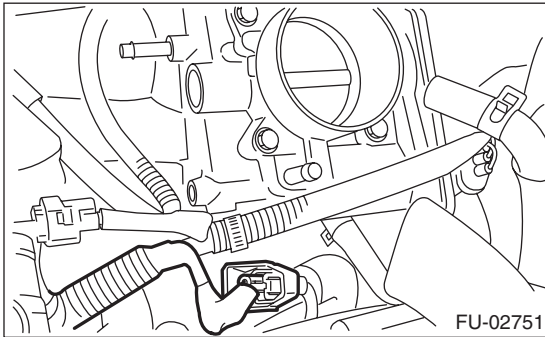

- 4) Remove the knock sensor from the cylinder block.

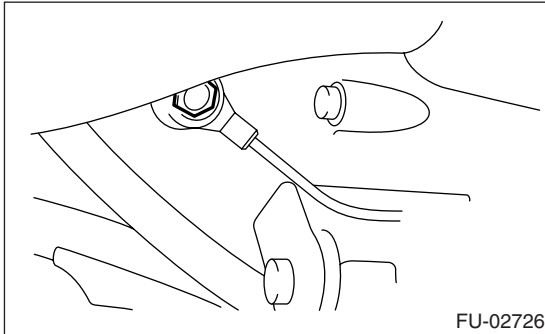

B: INSTALLATION

- 1) Install the knock sensor to the cylinder block.

Tightening torque:

24 N·m (2.4 kgf·m, 17.4 ft·lb)

NOTE:

Extraction area of the knock sensor cord must be positioned at a 60° angle relative to the engine rear.

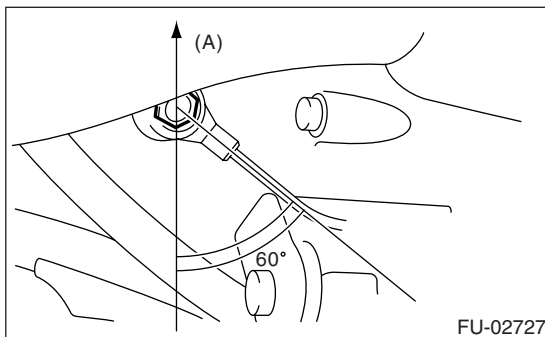

(A) Front side

- 2) Connect the knock sensor connector.

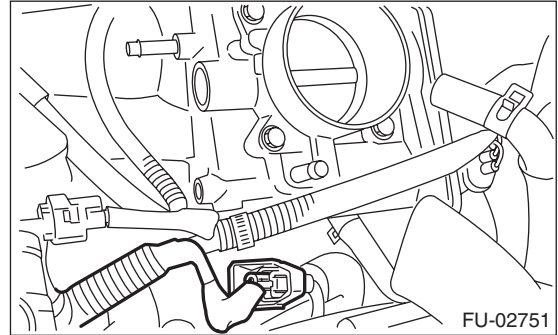

- 3) Install the intercooler. <Ref. to IN(H4DOTC)-11, INSTALLATION, Intercooler.>
- 4) Connect the battery ground cable to battery.

8. Mass Air Flow and Intake Air Temperature Sensor

A: REMOVAL

- 1) Disconnect the ground cable from battery.
- 2) Disconnect the connector from mass air flow and intake air temperature sensor.
- 3) Remove the mass air flow and intake air temperature sensor.

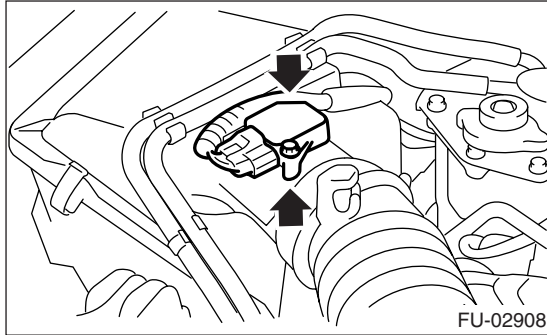

B: INSTALLATION

Install in the reverse order of removal.

Tightening torque:

1.7 N·m (0.17 kgf-m, 1.3 ft-lb)

Manifold Absolute Pressure Sensor

FUEL INJECTION (FUEL SYSTEMS)

9. Manifold Absolute Pressure Sensor

A: REMOVAL

- 1) Disconnect the ground cable from battery.
- 2) Disconnect the connectors from manifold absolute pressure sensor.

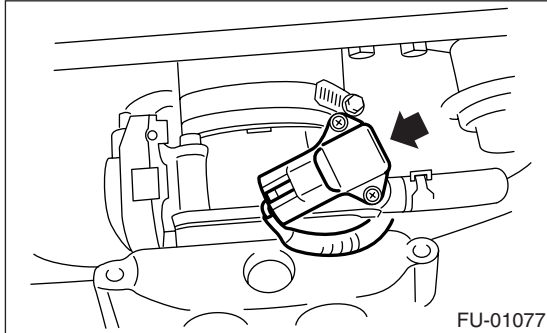

- 3) Remove the manifold absolute pressure sensor from the throttle body.

B: INSTALLATION

Install in the reverse order of removal.

NOTE:

Replace the O-rings for the manifold absolute pressure sensor with new ones.

Tightening torque:

1.6 N·m (0.16 kgf-m, 1.2 ft-lb)

10. Fuel Injector

A: REMOVAL

1. RH SIDE

- 1) Release the fuel pressure. <Ref. to FU(H4DOTC)-50, RELEASING OF FUEL PRESSURE, PROCEDURE, Fuel.>
- 2) Disconnect the ground cable from battery.
- 3) Open the fuel filler flap lid and remove the fuel filler cap.
- 4) Remove the air cleaner upper cover and air intake boot. <Ref. to IN(H4DOTC)-8, REMOVAL, Air Cleaner Case.>
- 5) Remove the air cleaner element.
- 6) Remove the coolant filler tank. <Ref. to CO(H4DOTC)-33, REMOVAL, Coolant Filler Tank.>
- 7) Remove the power steering pump.
 - (1) Remove the front side V-belt. <Ref. to ME(H4DOTC)-41, REMOVAL, V-belt.>
 - (2) Disconnect the power steering switch connector.

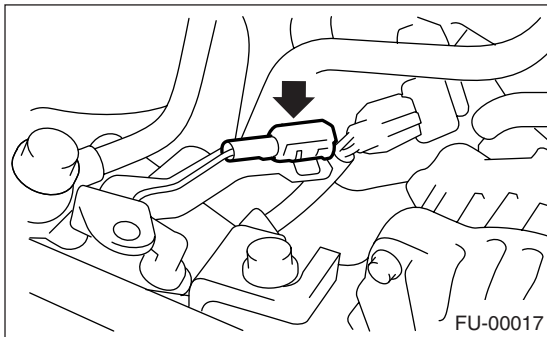

- (3) Remove the bolts which secure the power steering pipe brackets to the intake manifold.

NOTE:

Do not disconnect the power steering hose.

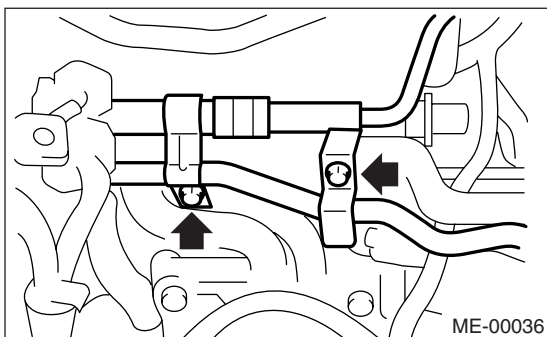

- (4) Remove the bolts which secure the power steering pump bracket.

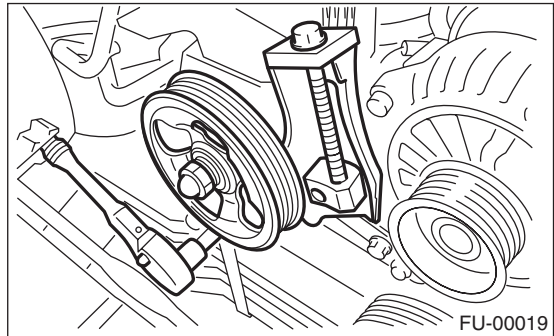

- (5) Remove the power steering tank from the bracket by pulling it upward.

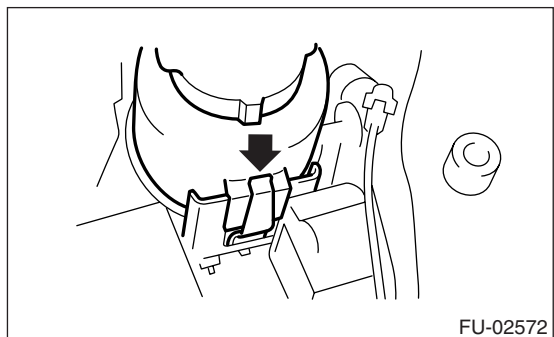

- (6) Place the power steering pump on the right side wheel apron.

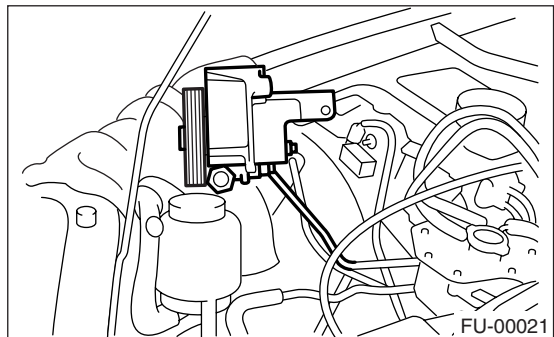

- 8) Remove the fuel pipe protector RH.

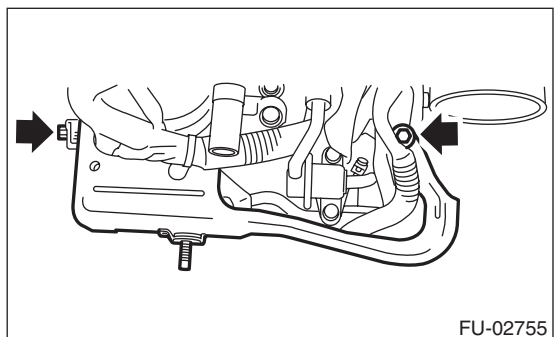

Fuel Injector

FUEL INJECTION (FUEL SYSTEMS)

9) Disconnect the connector from the fuel injector.

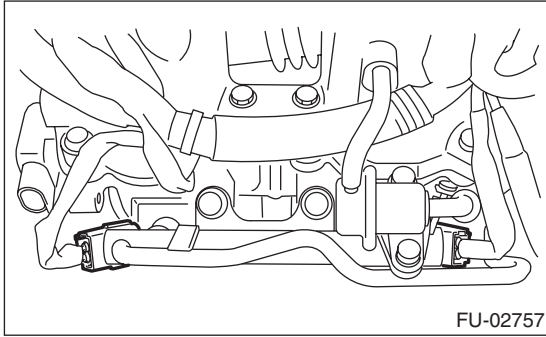

10) Remove the bolts which hold the injector pipe to intake manifold.

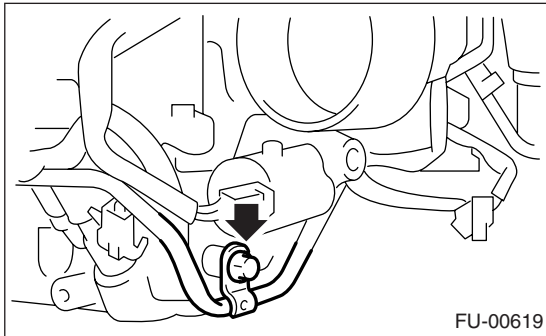
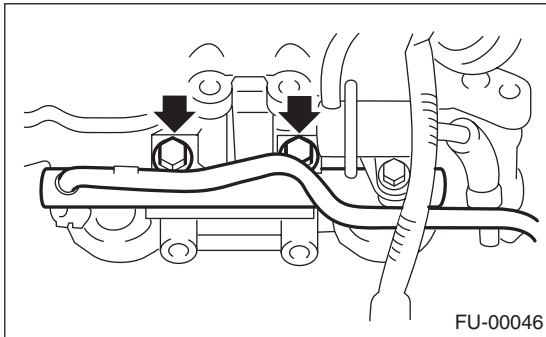

11) Remove the fuel injector while lifting up the fuel injector pipe.

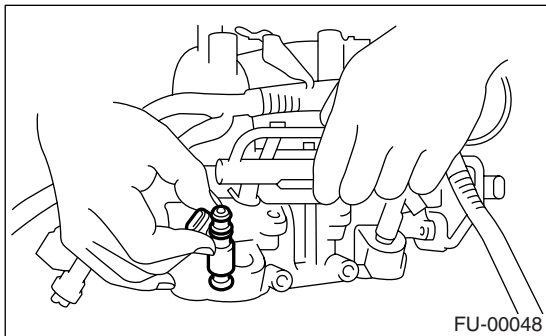

3) Open the fuel filler flap lid and remove the fuel filler cap.

4) Remove the intake manifold. <Ref. to FU(H4DOTC)-14, REMOVAL, Intake Manifold.>

5) Remove the fuel pipe protector LH.

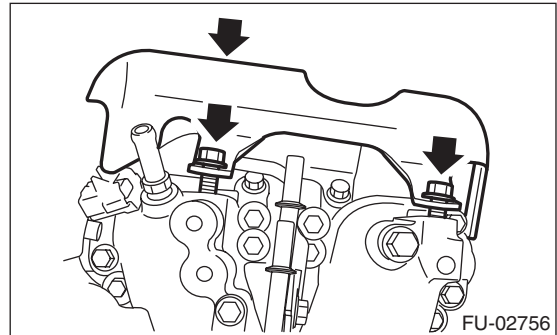

6) Disconnect the connector from the fuel injector.

7) Disconnect the connector from purge control solenoid valve.

8) Remove the purge control solenoid valve.

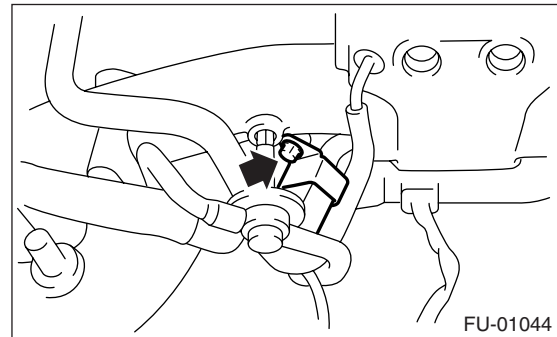

9) Remove the two bolts which hold the fuel injector pipe to the left side of intake manifold.

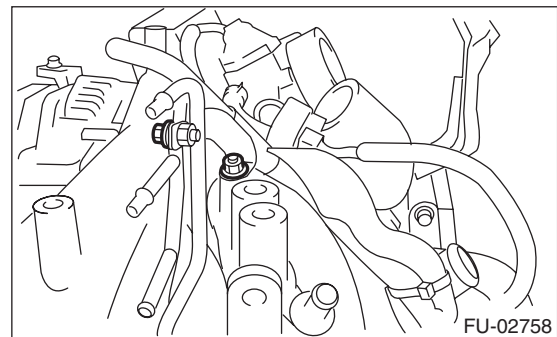

2. LH SIDE

1) Release the fuel pressure. <Ref. to FU(H4DOTC)-50, RELEASING OF FUEL PRESSURE, PROCEDURE, Fuel.>

2) Disconnect the ground cable from battery.

10) Remove the bolt which secure fuel injector pipe to intake manifold.

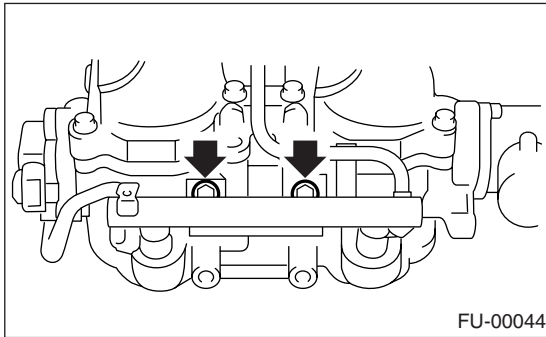
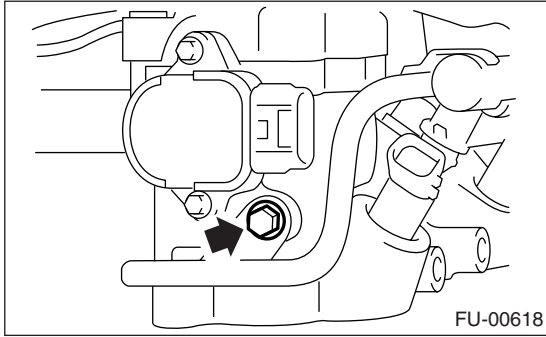

11) Remove the fuel injector while lifting up the fuel injector pipe.

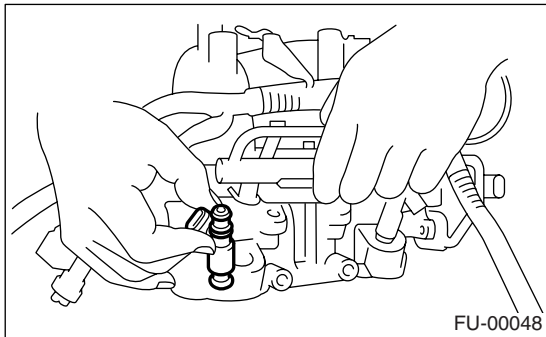

B: INSTALLATION

1. RH SIDE

Install in the reverse order of removal.

NOTE:

Replace the O-ring and insulators with new ones.

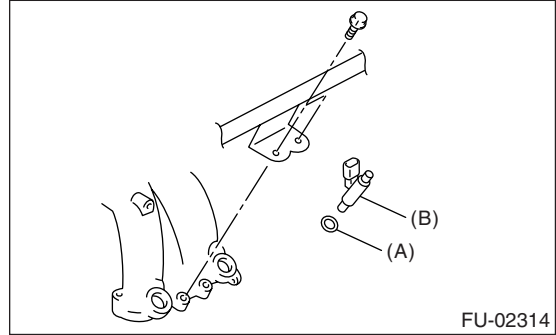

- (A) Insulator
- (B) Fuel injector

Tightening torque:

19 N·m (1.94 kgf-m, 13.7 ft-lb)

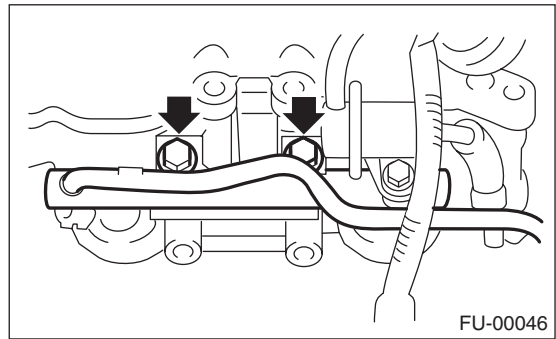

Tightening torque:

19 N·m (1.94 kgf-m, 13.7 ft-lb)

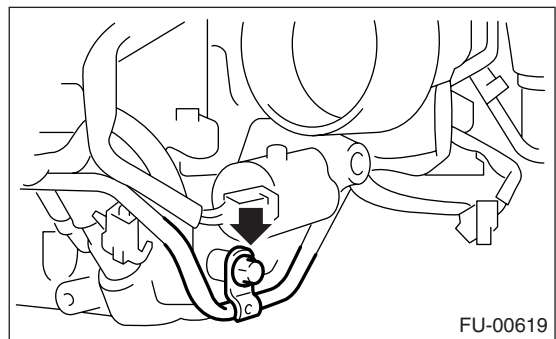

Fuel Injector

FUEL INJECTION (FUEL SYSTEMS)

Tightening torque:
19 N·m (1.94 kgf-m, 13.7 ft-lb)

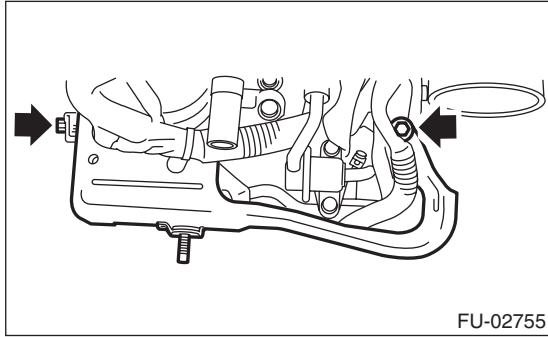

FU-02755

Tightening torque:
19 N·m (1.94 kgf-m, 13.7 ft-lb)

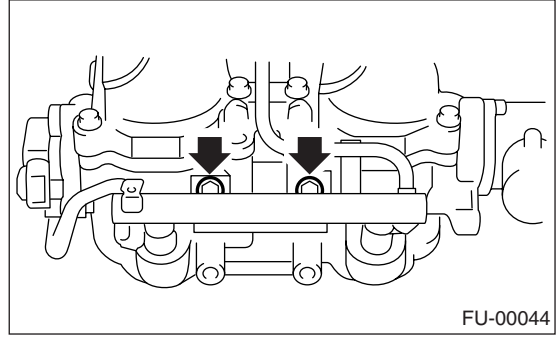

FU-00044

2. LH SIDE

Install in the reverse order of removal.

NOTE:

Replace the O-ring and insulators with new ones.

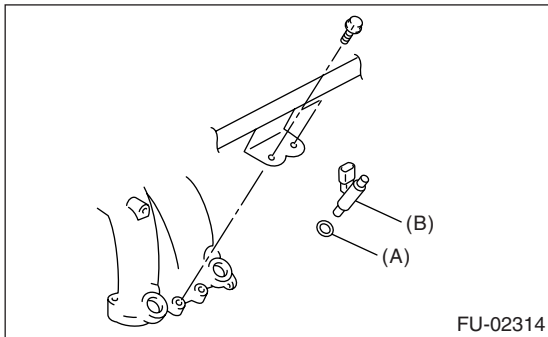

FU-02314

- (A) Insulator
- (B) Fuel injector

Tightening torque:
6.4 N·m (0.65 kgf-m, 4.7 ft-lb)

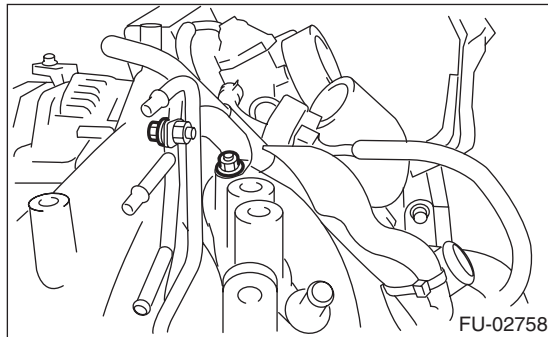

FU-02758

Tightening torque:
19 N·m (1.94 kgf-m, 13.7 ft-lb)

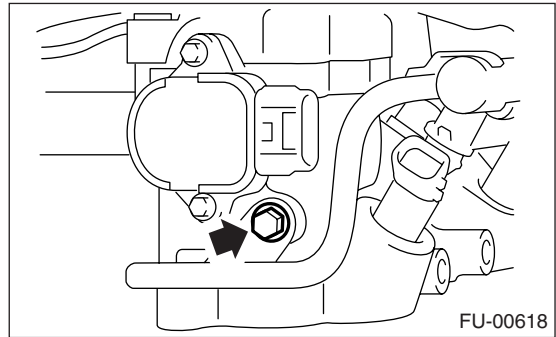

FU-00618

Tightening torque:
19 N·m (1.94 kgf-m, 13.7 ft-lb)

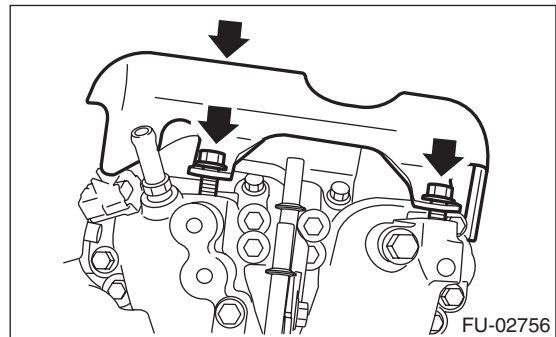

FU-02756

11. Tumble Generator Valve Assembly

A: REMOVAL

- 1) Release the fuel pressure. <Ref. to FU(H4DOTC)-50, RELEASING OF FUEL PRESSURE, PROCEDURE, Fuel.>
- 2) Disconnect the ground cable from battery.
- 3) Open the fuel filler flap lid and remove the fuel filler cap.
- 4) Remove the intake manifold. <Ref. to FU(H4DOTC)-14, REMOVAL, Intake Manifold.>
- 5) Disconnect the connector from the tumble generator valve sensor.

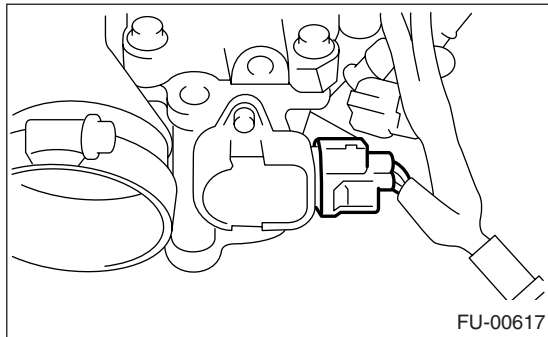

- 6) Disconnect the connector from the tumble generator valve actuator.

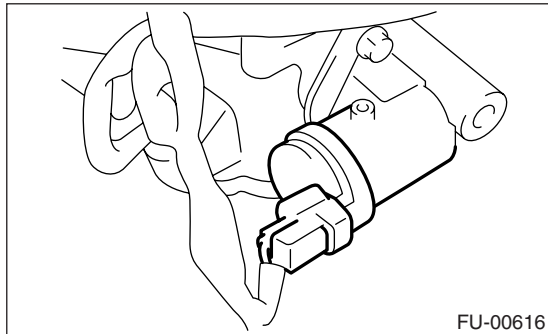

- 7) Remove the fuel injector. <Ref. to FU(H4DOTC)-33, REMOVAL, Fuel Injector.>
- 8) Remove the tumble generator valve body from the intake manifold.

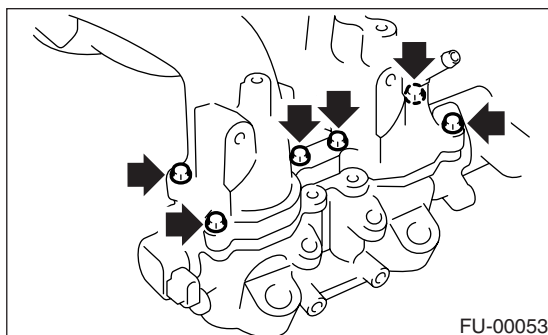

B: INSTALLATION

Install in the reverse order of removal.

NOTE:

Always use new gaskets.

Tightening torque:

8.25 N·m (0.84 kgf-m, 6.1 ft-lb)

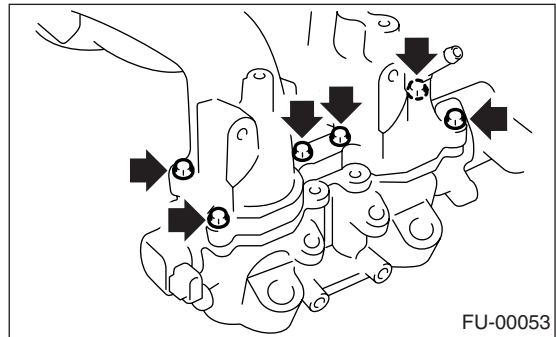

Tumble Generator Valve Position Sensor

FUEL INJECTION (FUEL SYSTEMS)

12. Tumble Generator Valve Position Sensor

A: SPECIFICATION

Do not remove the tumble generator valve position sensor from tumble generator valve assembly, since it cannot be adjusted during installation.

Refer to "Tumble Generator Valve Assembly" for removal and installation procedures. <Ref. to FU(H4DOTC)-37, REMOVAL, Tumble Generator Valve Assembly.> <Ref. to FU(H4DOTC)-37, INSTALLATION, Tumble Generator Valve Assembly.>

13. Tumble Generator Valve Actuator

A: REMOVAL

1. RH SIDE

- 1) Release the fuel pressure. <Ref. to FU(H4DOTC)-50, RELEASING OF FUEL PRESSURE, PROCEDURE, Fuel.>
- 2) Disconnect the ground cable from battery.
- 3) Open the fuel filler flap lid and remove the fuel filler cap.
- 4) Remove the intake manifold. <Ref. to FU(H4DOTC)-14, REMOVAL, Intake Manifold.>
- 5) Disconnect the connector from tumble generator valve actuator RH.
- 6) Remove the tumble generator valve actuator RH.

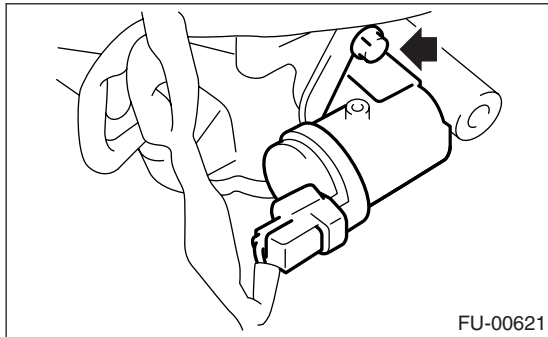

2. LH SIDE

- 1) Release the fuel pressure. <Ref. to FU(H4DOTC)-50, RELEASING OF FUEL PRESSURE, PROCEDURE, Fuel.>
- 2) Disconnect the ground cable from battery.
- 3) Open the fuel filler flap lid and remove the fuel filler cap.
- 4) Remove the secondary air pump. <Ref. to EC(H4DOTC)-9, REMOVAL, Secondary Air Pump.>
- 5) Disconnect the connector from tumble generator valve actuator LH.
- 6) Remove the tumble generator valve actuator LH.

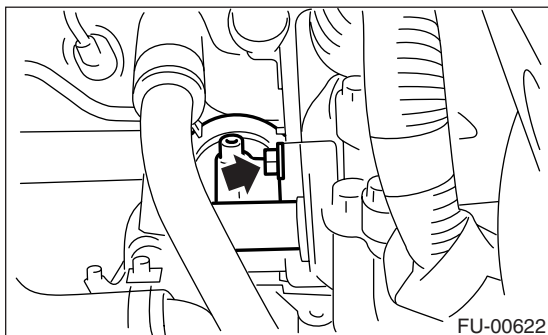

B: INSTALLATION

1. RH SIDE

Install in the reverse order of removal.

2. LH SIDE

Install in the reverse order of removal.

Wastegate Control Solenoid Valve

FUEL INJECTION (FUEL SYSTEMS)

14. Wastegate Control Solenoid Valve

A: REMOVAL

- 1) Disconnect the ground cable from battery.
- 2) Disconnect the engine harness connector (A) from bracket.
- 3) Disconnect the connector (B) from wastegate control solenoid valve.
- 4) Remove the bracket from body.

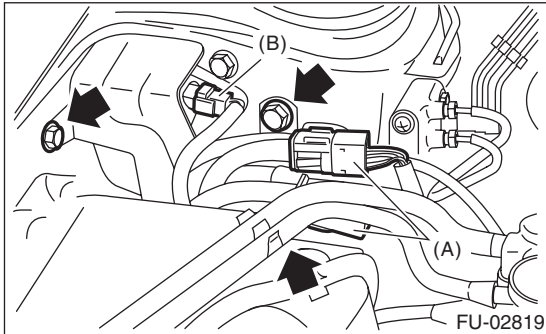

- 5) Disconnect the pressure hoses (C) from wastegate control solenoid valve.

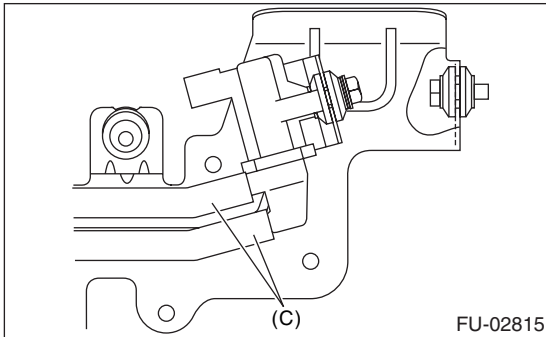

- 6) Remove the wastegate control solenoid valve from bracket.

B: INSTALLATION

Install in the reverse order of removal.

Tightening torque:

6.4 N·m (0.65 kgf-m, 4.7 ft-lb)

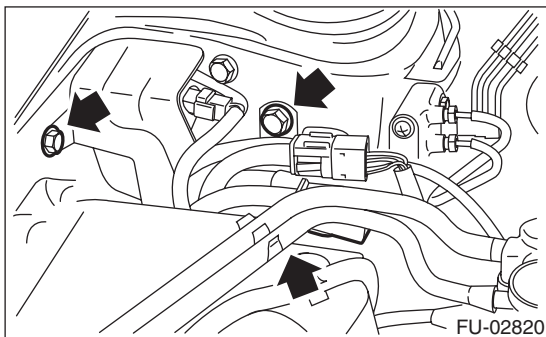

Front Oxygen (A/F) Sensor

FUEL INJECTION (FUEL SYSTEMS)

15. Front Oxygen (A/F) Sensor

A: REMOVAL

- 1) Disconnect the ground cable from battery.
- 2) Disconnect the connector from the front oxygen (A/F) sensor.

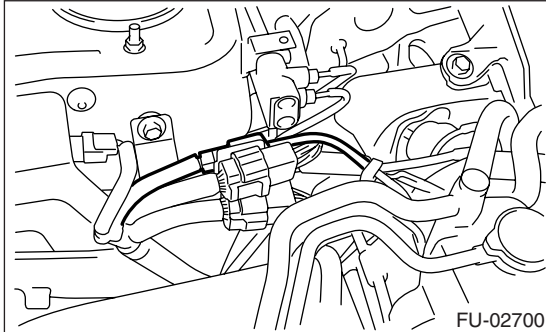

- 3) Disconnect the engine harness fixed by clip (A) from the bracket (B).

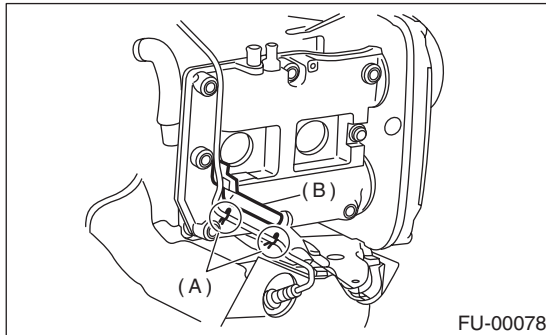

- 4) Remove the front right side wheel.
- 5) Lift-up the vehicle.
- 6) Remove the service hole cover.

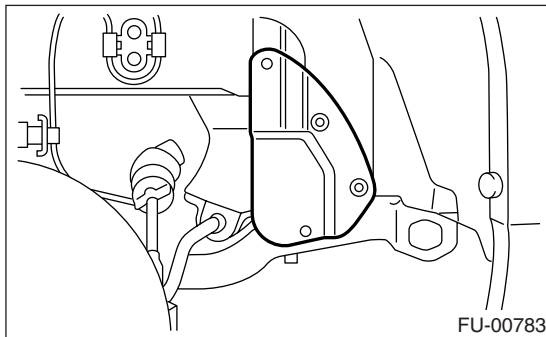

- 7) Apply spray type lubricant to the threaded portion of front oxygen (A/F) sensor, and leave it for one minute or more.
- 8) Remove the front oxygen (A/F) sensor.

CAUTION:

When removing the front oxygen (A/F) sensor, wait until exhaust pipe cools, otherwise it will damage exhaust pipe.

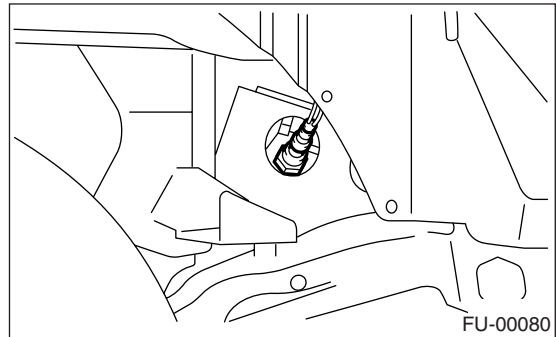

B: INSTALLATION

- 1) Before installing front oxygen (A/F) sensor, apply anti-seize compound only to the threaded portion of front oxygen (A/F) sensor to make the next removal easier.

Anti-seize compound:

NEVER-SEEZ NS-165 or equivalent

CAUTION:

Never apply anti-seize compound to protector of front oxygen (A/F) sensor.

- 2) Install the front oxygen (A/F) sensor.

Tightening torque:

30 N·m (3.1 kgf-m, 22.1 ft-lb)

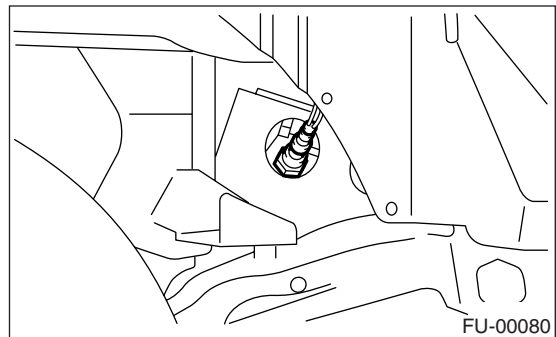

- 3) Install the service hole cover.

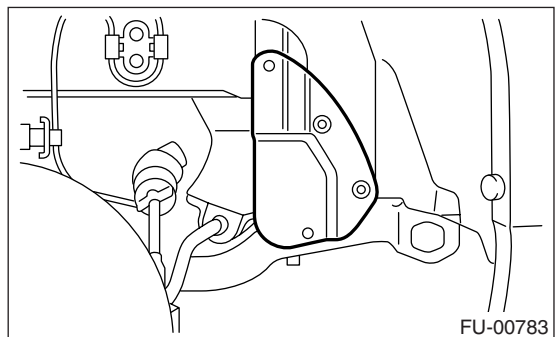

- 4) Lower the vehicle.
- 5) Install the front right side wheel.

Front Oxygen (A/F) Sensor

FUEL INJECTION (FUEL SYSTEMS)

6) Connect the engine harness to the bracket (B) using clips (A).

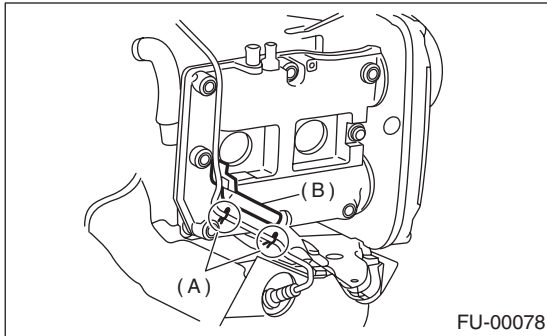

7) Connect the connector of front oxygen (A/F) sensor.

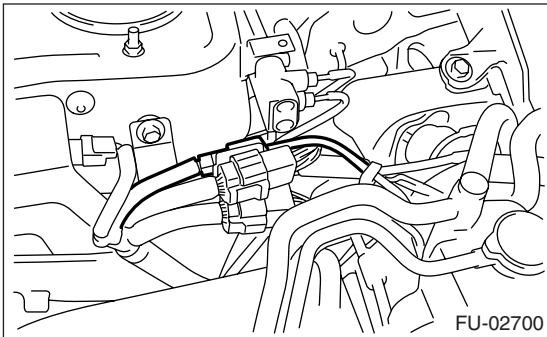

8) Connect the battery ground cable to battery.

16.Rear Oxygen Sensor

A: REMOVAL

- 1) Disconnect the ground cable from battery.
- 2) Lift-up the vehicle.
- 3) Disconnect the connector from the rear oxygen sensor.

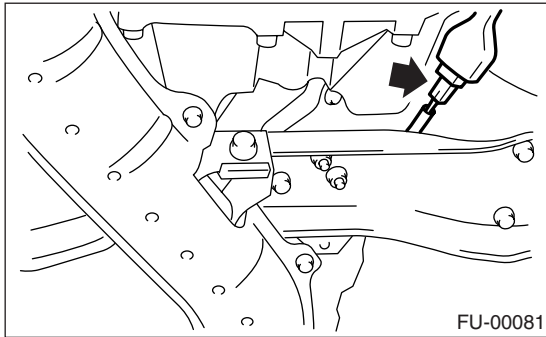

- 4) Remove the clip by pulling out from the upper side of crossmember.

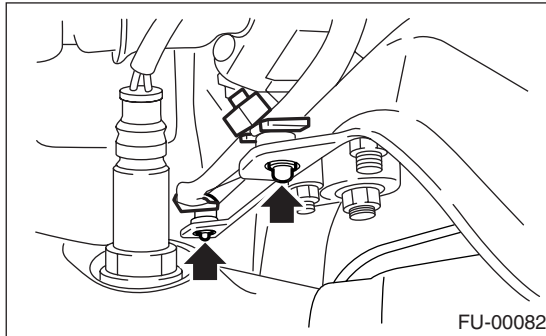

- 5) Apply spray type lubricant to the threaded portion of rear oxygen sensor, and leave it for one minute or more.
- 6) Remove the rear oxygen sensor.

CAUTION:

When removing the rear oxygen sensor, wait until exhaust pipe cools, otherwise it will damage exhaust pipe.

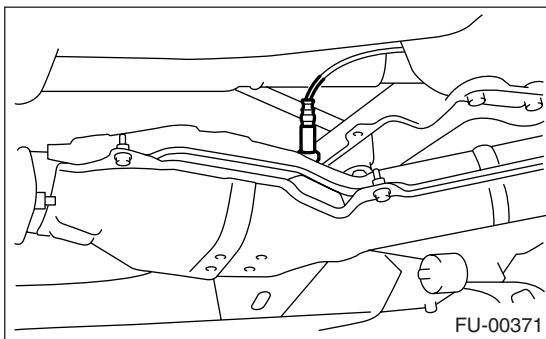

B: INSTALLATION

- 1) Before installing rear oxygen sensor, apply anti-seize compound only to the threaded portion of rear oxygen sensor to make the next removal easier.

CAUTION:

Never apply anti-seize compound to protector of rear oxygen sensor.

Anti-seize compound:

NEVER-SEEZ NS-165 or equivalent

- 2) Install the rear oxygen sensor.

Tightening torque:

21 N·m (2.1 kgf-m, 15.2 ft-lb)

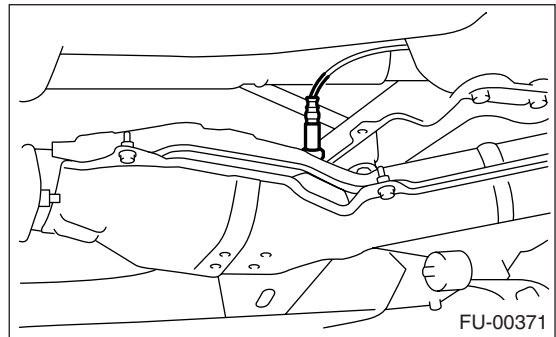

- AT model

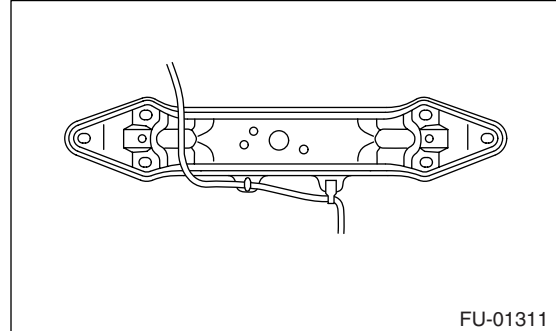

- MT model

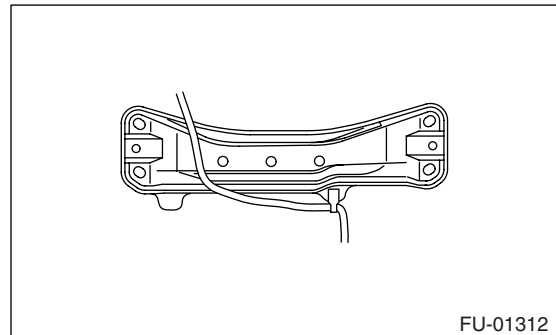

Rear Oxygen Sensor

FUEL INJECTION (FUEL SYSTEMS)

- 3) Connect the connector to the rear oxygen sensor.

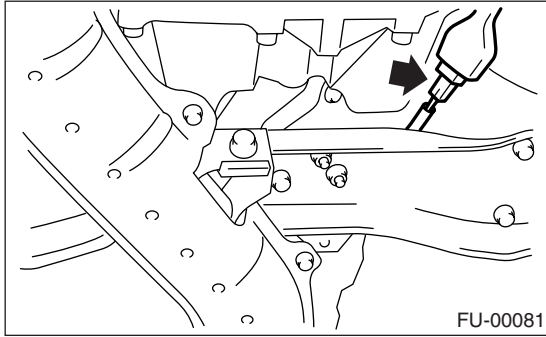

- 4) Connect the clip to the crossmember.

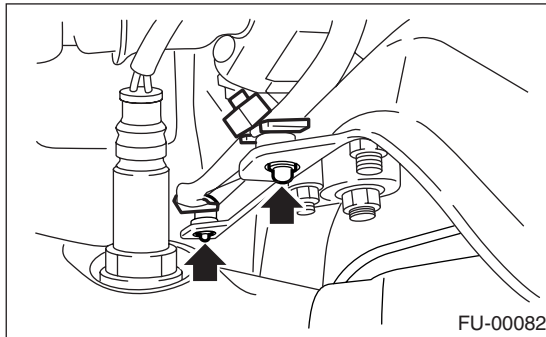

- 5) Lower the vehicle.
6) Connect the battery ground cable to battery.

17.Engine Control Module (ECM)

A: REMOVAL

- 1) Disconnect the ground cable from battery.
- 2) Remove the lower inner trim of the passenger side. <Ref. to EI-51, REMOVAL, Lower Inner Trim.>
- 3) Detach the floor mat of the front passenger seat.
- 4) Remove the protect cover.

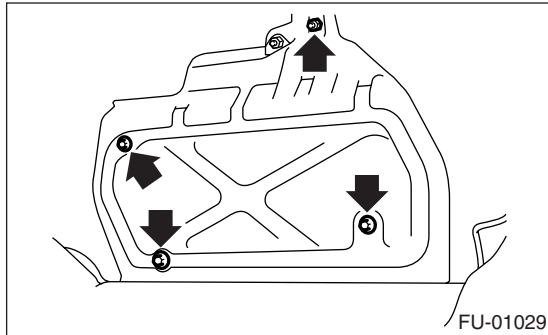

- 5) Remove the nuts (A) which hold ECM to the bracket.
- 6) Remove the clip (B) from the bracket.

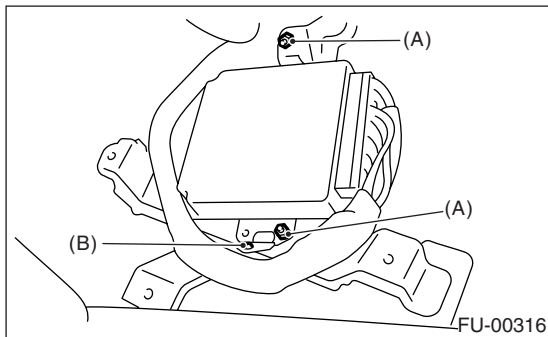

- 7) Disconnect the ECM connectors and take out the ECM.

B: INSTALLATION

Install in the reverse order of removal.

CAUTION:

- When replacing ECM, use of wrong spec. ECM may lead to damage to the fuel injection system.
- When replacing ECM, do not damage the harnesses and connectors.

Tightening torque:

5 N·m (0.5 kgf-m, 3.7 ft-lb)

18.Main Relay

A: REMOVAL

- 1) Disconnect the ground cable from battery.
- 2) Remove the passenger's side front side sill cover.
- 3) Remove the bolt which holds the relay bracket on the body.
- 4) Disconnect the connectors from the main relay.

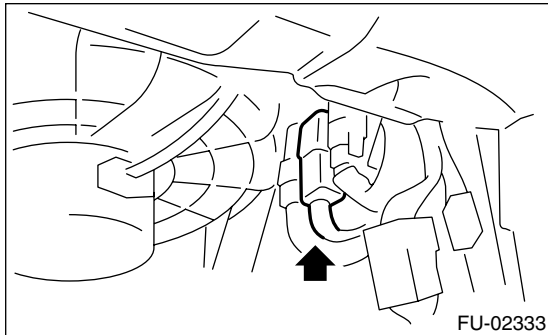

- 5) Remove the main relay from the mounting bracket.

B: INSTALLATION

Install in the reverse order of removal.

19. Fuel Pump Relay

A: REMOVAL

- 1) Disconnect the ground cable from battery.
- 2) Remove the passenger's side front side sill cover.
- 3) Remove the bolt which holds relay bracket on the body.
- 4) Disconnect the connector from the fuel pump relay.

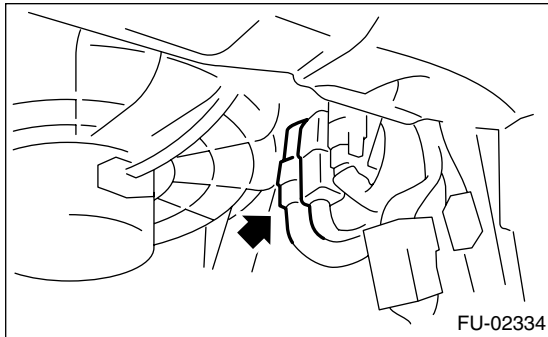

- 5) Remove the fuel pump relay from the mounting bracket.

B: INSTALLATION

Install in the reverse order of removal.

Electronic Throttle Control Relay

FUEL INJECTION (FUEL SYSTEMS)

20. Electronic Throttle Control Relay

A: REMOVAL

- 1) Disconnect the ground cable from battery.
- 2) Remove the passenger's side front side sill cover.
- 3) Remove the bolt which holds relay bracket on the body.
- 4) Disconnect the connector from electronic throttle control relay.

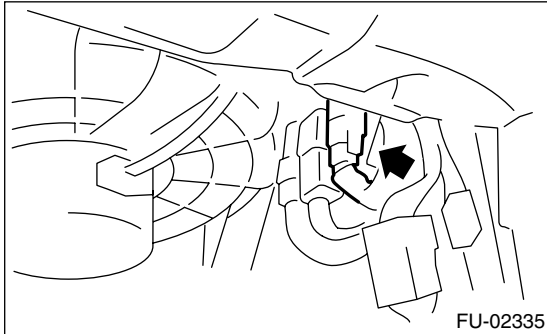

- 5) Remove the electronic throttle control relay from the mounting bracket.

B: INSTALLATION

Install in the reverse order of removal.

21. Fuel Pump Control Unit

A: REMOVAL

- 1) Disconnect the ground cable from battery.
- 2) Remove the rear quarter trim. <Ref. to EI-52, REMOVAL, Rear Quarter Trim.>
- 3) Disconnect the connector from the fuel pump control unit.

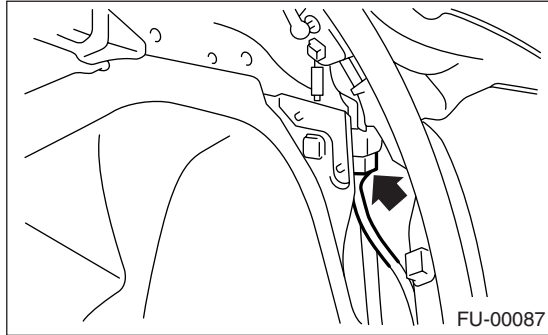

- 4) Remove the fuel pump control unit.

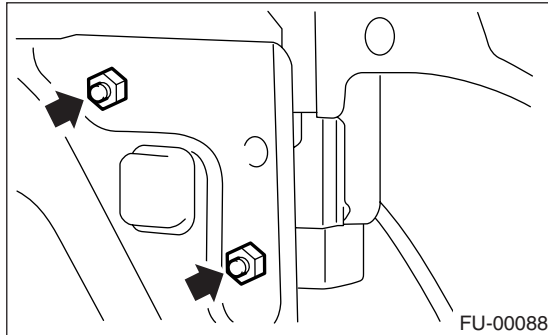

B: INSTALLATION

Install in the reverse order of removal.

22. Fuel

A: PROCEDURE

1. RELEASING OF FUEL PRESSURE

WARNING:

- Place “NO FIRE” signs near the working area.
- Be careful not to spill the fuel.

- 1) Disconnect the connector from the fuel pump relay.

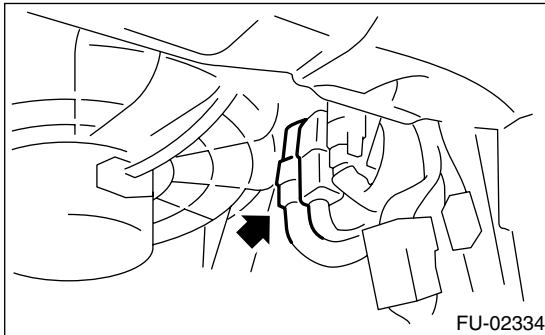

- 2) Start and run the engine until it stalls.
- 3) After the engine stalls, crank it for five more seconds.
- 4) Turn the ignition switch to OFF.

2. DRAINING FUEL

WARNING:

- Place “NO FIRE” signs near the working area.
- Be careful not to spill the fuel.

- 1) Set the vehicle on the lift.
- 2) Disconnect the ground cable from battery.
- 3) Open the fuel filler flap lid and remove the fuel filler cap.
- 4) Lift-up the vehicle.
- 5) Drain the fuel from the fuel tank.
Set a container under the vehicle and remove drain plug from the fuel tank.

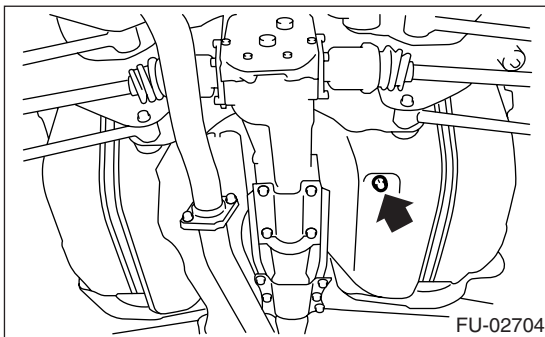

- 6) Tighten the fuel drain plug.

NOTE:

Use a new gasket.

Tightening torque:

26 N·m (2.65 kgf-m, 19.2 ft-lb)

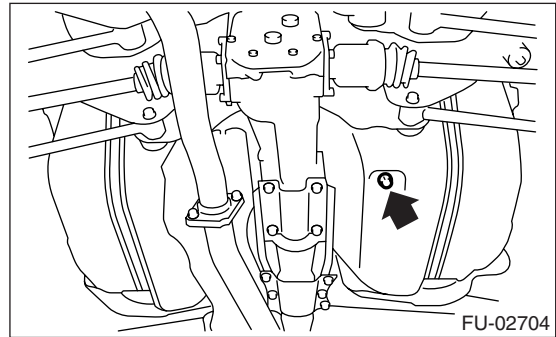

23. Fuel Tank

A: REMOVAL

WARNING:

- Place “NO FIRE” signs near the working area.
- Be careful not to spill the fuel.

- 1) Set the vehicle on the lift.
- 2) Release the fuel pressure. <Ref. to FU(H4DOTC)-50, RELEASING OF FUEL PRESSURE, PROCEDURE, Fuel.>
- 3) Drain the fuel from the fuel tank. <Ref. to FU(H4DOTC)-50, DRAINING FUEL, PROCEDURE, Fuel.>
- 4) Remove the rear seat.
- 5) Disconnect the connector (A) of rear harness from fuel tank cord.
- 6) Push the grommet (B) which holds the fuel tank cord on floor panel into under the body.

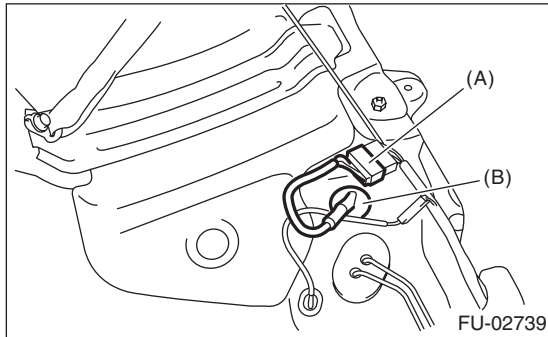

- 7) Remove the rear crossmember. <Ref. to RS-17, REMOVAL, Rear Crossmember.>
- 8) Remove the canister. <Ref. to EC(H4DOTC)-7, REMOVAL, Canister.>
- 9) Disconnect the connector from the pressure control solenoid valve.

- 10) Loosen the clamp, and disconnect the fuel filler hose (A) and evaporation hose (B) from fuel filler pipe.

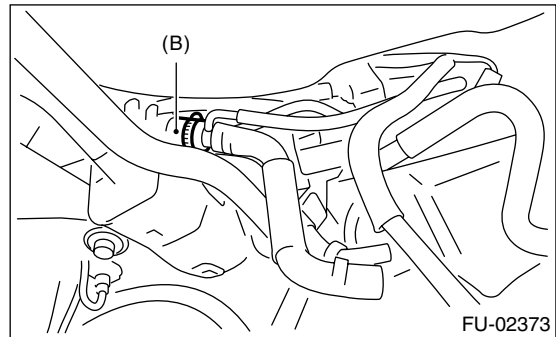
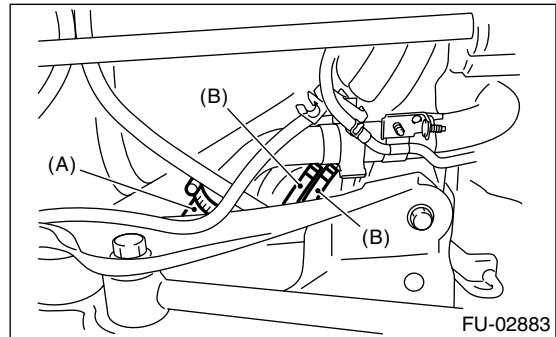

- 11) Move the clips, and disconnect the quick connector. <Ref. to FU(H4DOTC)-65, REMOVAL, Fuel Delivery, Return and Evaporation lines.>
- 12) Disconnect the fuel hoses.

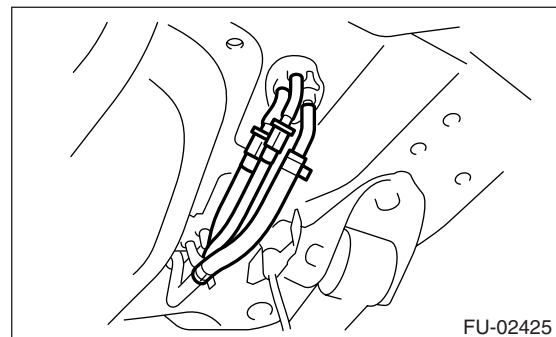

- 13) Support the fuel tank with transmission jack, remove the bolts from bands and dismount the fuel tank from vehicle.

Fuel Tank

FUEL INJECTION (FUEL SYSTEMS)

WARNING:

- A helper is required to perform this work.
- Fuel may be left in the side, which has no drain plug, of the fuel tank. In this case, the tank is imbalanced between right and left sides. Be careful not to drop it when removing.

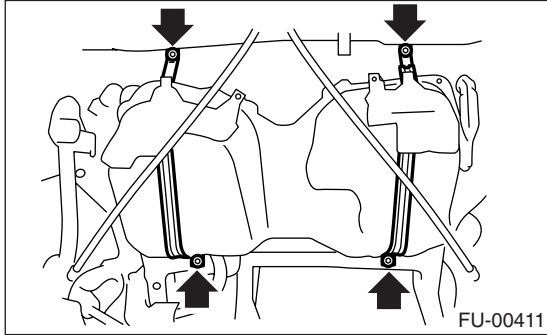

B: INSTALLATION

- 1) Support the fuel tank with transmission jack and push the fuel tank harness into the access hole with grommet.
- 2) Set the fuel tank and temporarily tighten the bolts of fuel tank bands.

WARNING:

A helper is required to perform this work.

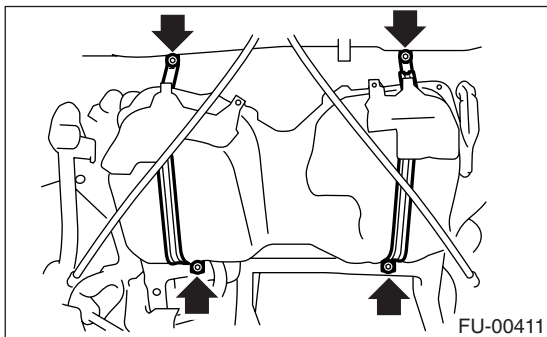

- 3) Insert the fuel filler hose (A) approx. 35 to 40 mm (1.38 to 1.57 in) over the lower end of fuel filler pipe and tighten the clamp.
- 4) Insert the evaporation hose (B) to the lower end of evaporation pipe, and hold the clamp and clip.

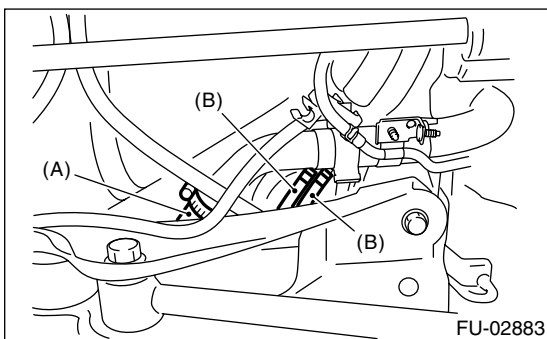

CAUTION:

Do not allow clips to touch hose (A) and rear suspension crossmember.

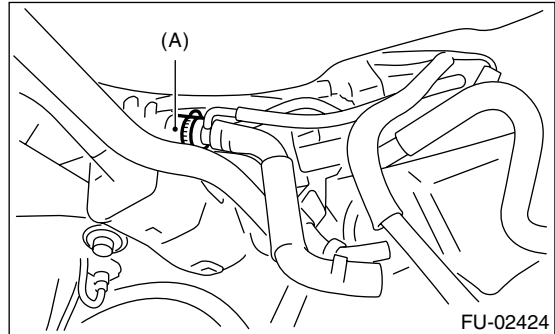

- 5) Connect the fuel hoses, and hold them with clips and quick connector. <Ref. to FU(H4DOTC)-66, INSTALLATION, Fuel Delivery, Return and Evaporation lines.>

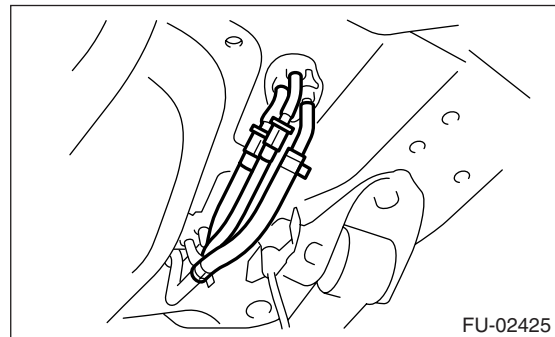

- 6) Connect the connector to the pressure control solenoid valve.
- 7) Install the canister. <Ref. to EC(H4DOTC)-7, INSTALLATION, Canister.>
- 8) Tighten the band mounting bolts.

Tightening torque:

33 N·m (3.4 kgf-m, 25 ft-lb)

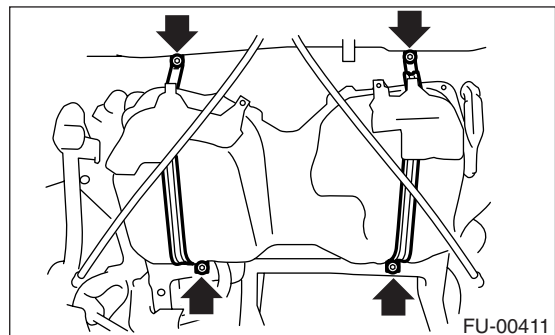

- 9) Install the rear crossmember. <Ref. to RS-17, INSTALLATION, Rear Crossmember.>

- 10) Connect the connector (A) to the fuel tank cord and plug the service hole with grommet (B).

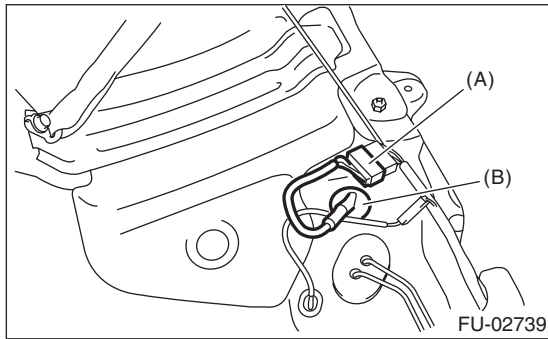

- 11) Set the rear seat and floor mat.
- 12) Connect the connector to the fuel pump relay.

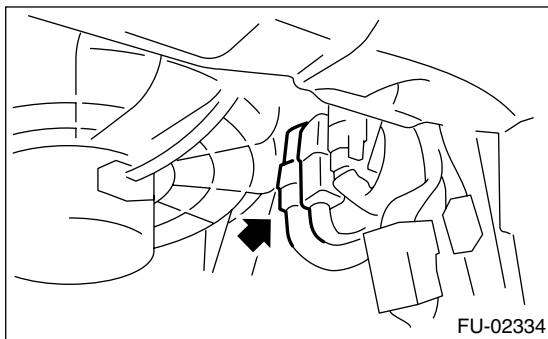

C: INSPECTION

- 1) Make sure there are no cracks, holes, or other damage on the fuel tank.
- 2) Make sure that the fuel hoses and fuel pipes are not cracked and the connections are tightened firmly.

Fuel Filler Pipe

FUEL INJECTION (FUEL SYSTEMS)

24. Fuel Filler Pipe

A: REMOVAL

WARNING:

- Place “NO FIRE” signs near the working area.
- Be careful not to spill fuel on the floor.

- 1) Disconnect the ground cable from battery.
- 2) Open the fuel filler flap lid and remove the filler cap.
- 3) Remove the screws holding packing in place.

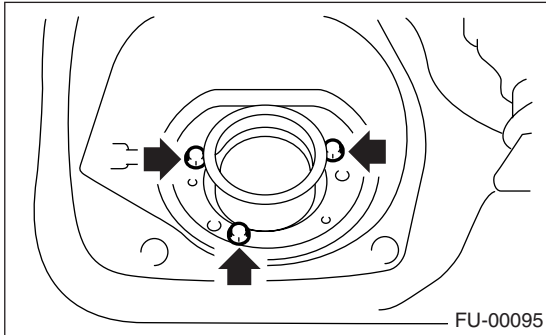

- 4) Lift up the vehicle.
- 5) Remove the rear right side wheel nuts.
- 6) Remove the rear right side wheel.

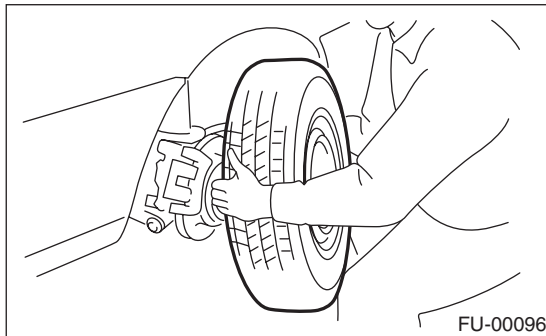

- 7) Drain the fuel from the fuel tank. <Ref. to FU(H4DOTC)-50, DRAINING FUEL, PROCEDURE, Fuel.>

- 8) Remove the fuel filler pipe protector.

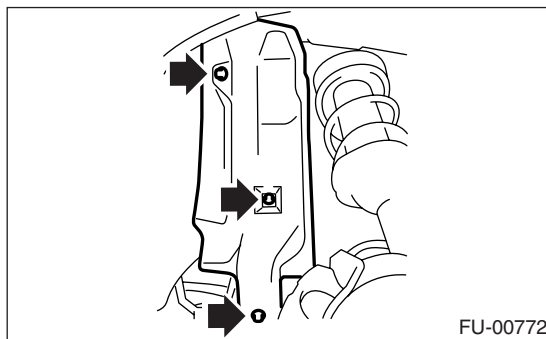

- 9) Separate the evaporation hoses from the clip of fuel filler pipe.

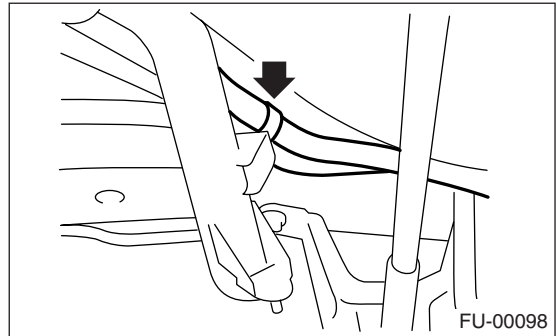

- 10) Disconnect the evaporation hoses from fuel pipes.

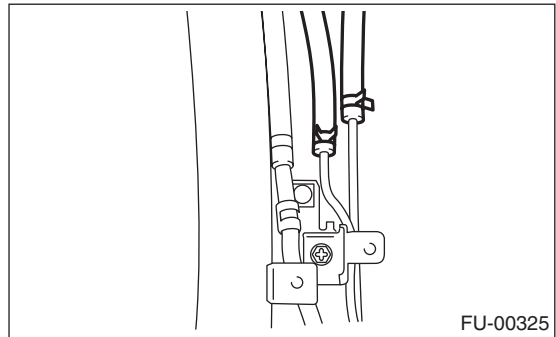

- 11) Remove the bolts which hold the fuel filler pipe bracket on the body.

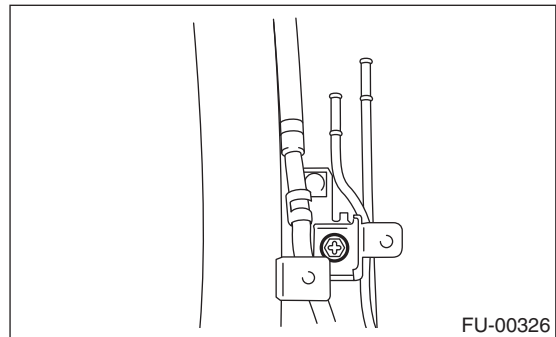

- 12) Loosen the clamp and separate the fuel filler hose (A) from the fuel filler pipe.

- 13) Move the clip and separate the evaporation hose (B).

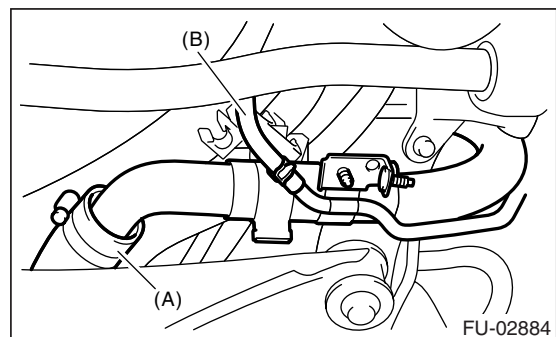

- 14) Remove the fuel filler pipe to under side of the vehicle.

Fuel Filler Pipe

15) Remove the evaporation pipe together with clip from the body.

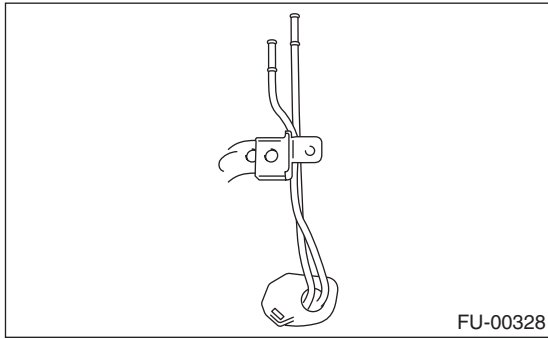

5) Connect the evaporation hoses to fuel pipes.

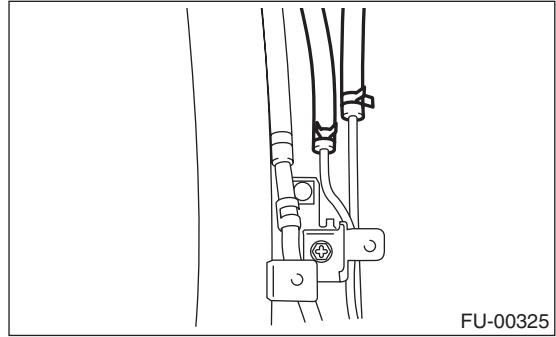

B: INSTALLATION

- 1) Open the fuel filler flap lid.
- 2) Set the fuel saucer (A) with rubber packing (C) and insert the fuel filler pipe into hole from the inner side of apron.
- 3) Align the holes in fuel filler pipe neck and set the cup (B), and tighten the screws.

NOTE:

If the edges of rubber packing are folded toward the inside, straighten it with a screwdriver.

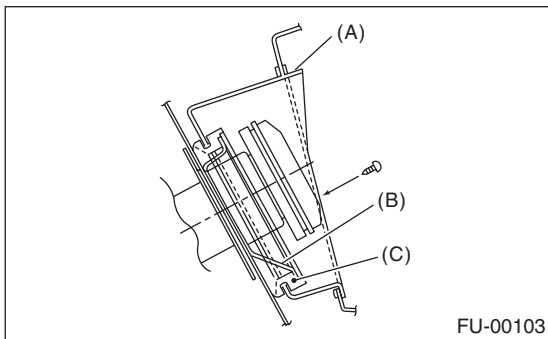

6) Insert the fuel filler hose (A) approximately 35 to 40 mm (1.38 to 1.57 in) over the lower end of fuel filler pipe and tighten the clamp.

7) Insert the evaporation hose (B) approximately 25 to 30 mm (0.98 to 1.18 in) into the lower end of evaporation pipe and hold the clip.

CAUTION:

Do not allow clips to touch evaporation hose (B) and rear suspension crossmember.

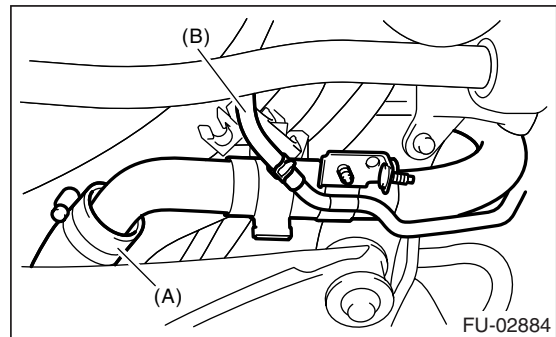

$L = 27.5 \pm 2.5 \text{ mm (1.083} \pm 0.098 \text{ in)}$

4) Install the evaporation pipe.

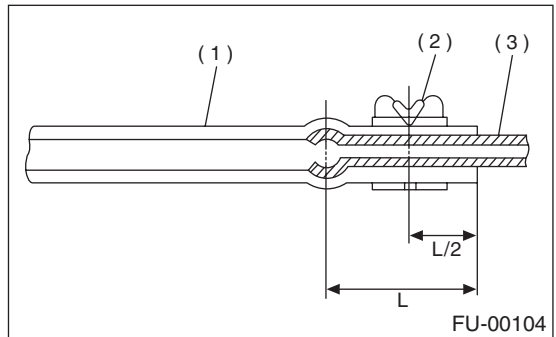
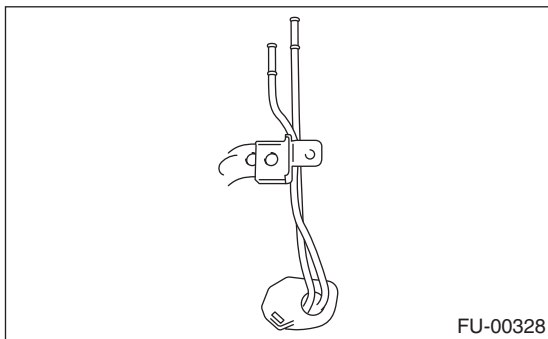

- (1) Hose
- (2) Clip
- (3) Pipe

8) Tighten the bolt which holds the fuel filler pipe bracket on the body.

Fuel Filler Pipe

FUEL INJECTION (FUEL SYSTEMS)

Tightening torque:

7.5 N·m (0.76 kgf-m, 5.5 ft-lb)

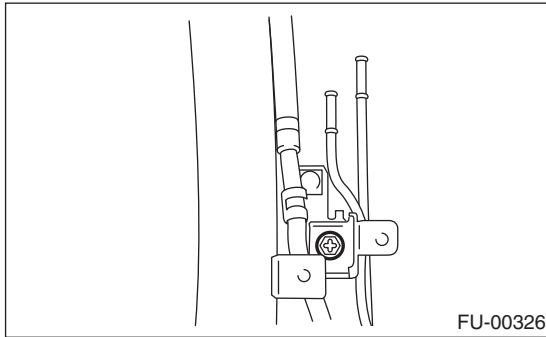

9) Secure the evaporation hose to clip of fuel filler pipe.

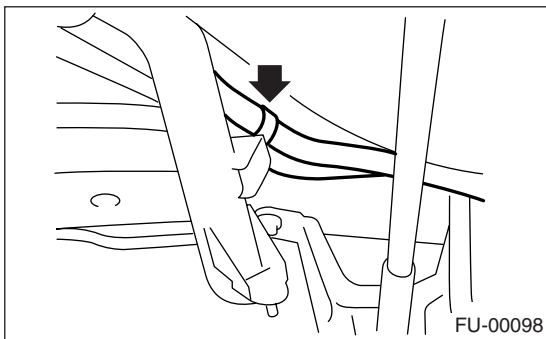

10) Install the fuel filler pipe protector.

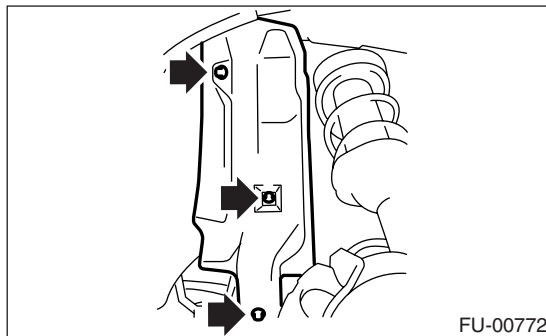

11) Install the rear right wheel.

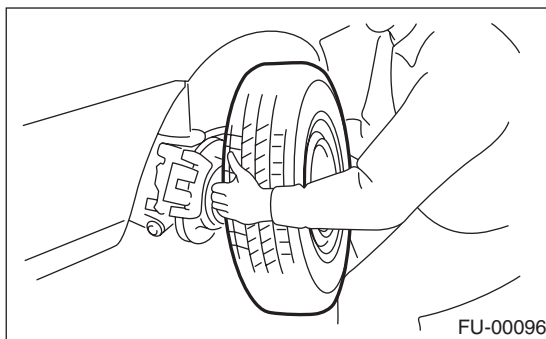

12) Lower the vehicle.

13) Tighten the wheel nuts.

14) Connect the battery ground cable to battery.

C: DISASSEMBLY

1) Move the clamp, and disconnect the evaporation hose from the joint pipe.

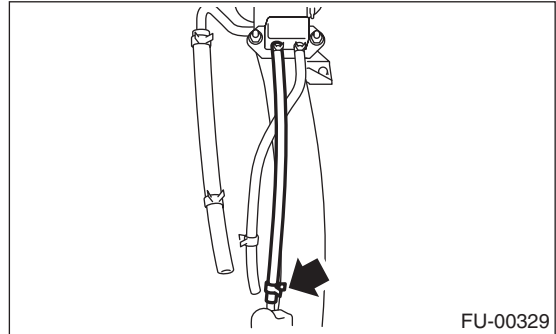

2) Remove the bolt which installs the joint pipe on the fuel filler pipe.

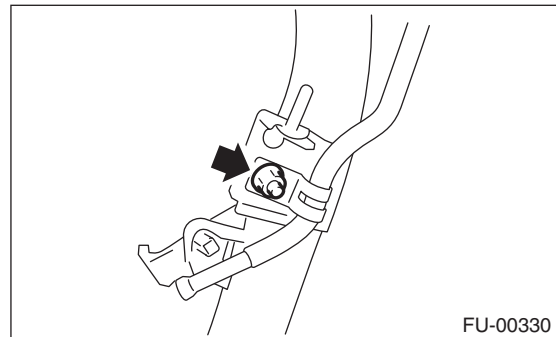

3) Disconnect the evaporation hose from the fuel filler pipe.

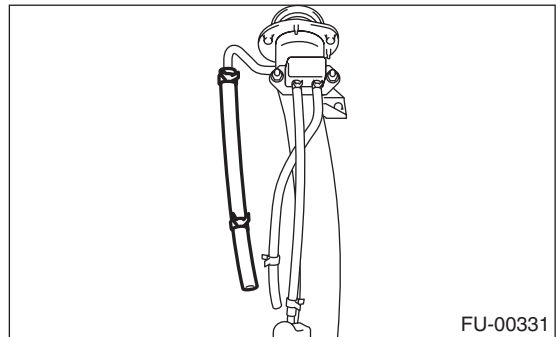

4) Remove the shut valve from the fuel filler pipe.
<Ref. to EC(H4DOTC)-19, REMOVAL, Shut Valve.>

D: ASSEMBLY

- 1) Install the shut valve on the fuel filler pipe. <Ref. to EC(H4DOTC)-7, INSTALLATION, Canister.>
- 2) Connect the evaporation hose to the fuel filler pipe.

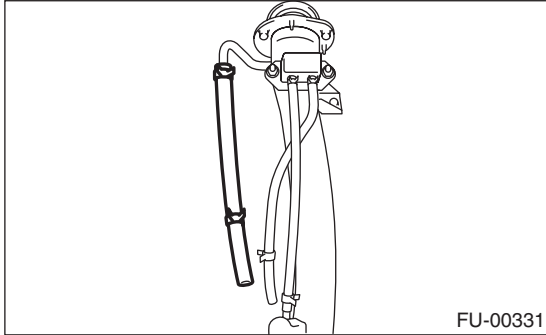

- 3) Connect the evaporation hose to the evaporation pipe.

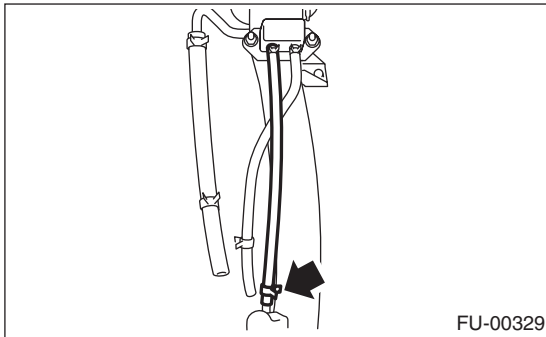

- 4) Install the evaporation pipe to the fuel filler pipe.

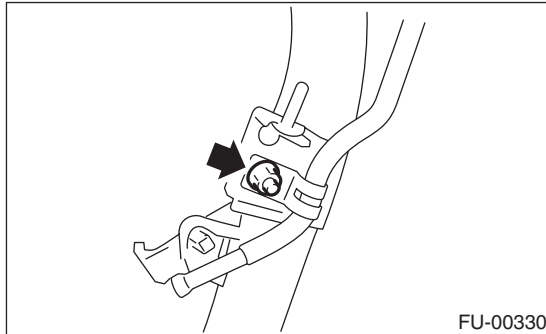

Fuel Pump

FUEL INJECTION (FUEL SYSTEMS)

25. Fuel Pump

A: REMOVAL

WARNING:

- Place “NO FIRE” signs near the working area.
- Be careful not to spill fuel on the floor.

NOTE:

The fuel pump assembly consists of a fuel pump and a fuel level sensor.

- 1) Release the fuel pressure. <Ref. to FU(H4DOTC)-50, RELEASING OF FUEL PRESSURE, PROCEDURE, Fuel.>
- 2) Disconnect the ground cable from battery.
- 3) Open the fuel filler flap lid and remove the fuel filler cap.
- 4) Lift up the vehicle.
- 5) Drain the fuel from the fuel tank. <Ref. to FU(H4DOTC)-50, DRAINING FUEL, PROCEDURE, Fuel.>
- 6) Remove the luggage floor mat. <Ref. to EI-61, REMOVAL, Luggage Floor Mat.>
- 7) Remove the service hole cover.

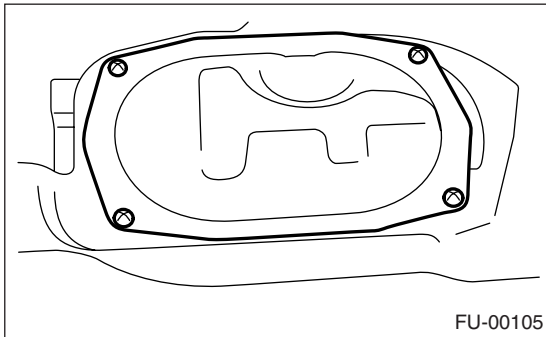

- 8) Disconnect the connector from fuel pump.

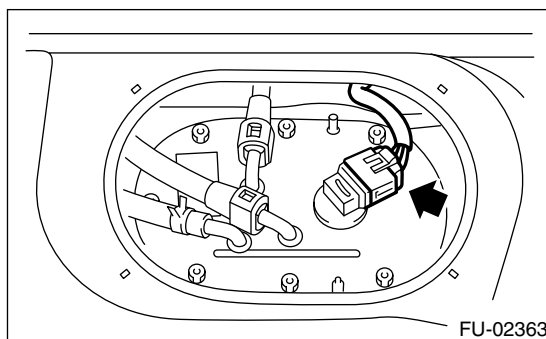

- 9) Disconnect the quick connector and then disconnect the fuel delivery hose and return hose. <Ref. to FU(H4DOTC)-65, REMOVAL, Fuel Delivery, Return and Evaporation lines.>

- 10) Move the clip and then disconnect the jet pump hose (A).

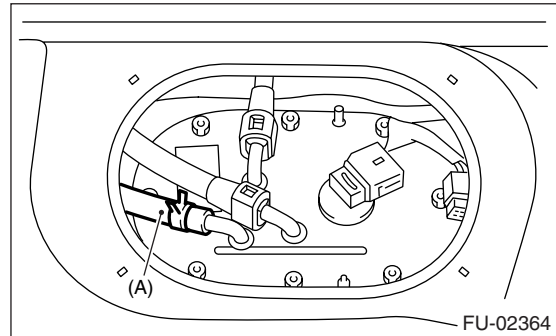

- 11) Remove the nuts which install the fuel pump assembly onto the fuel tank.

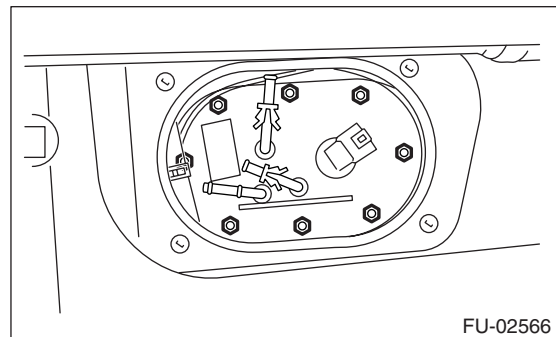

- 12) Take off the fuel pump assembly from the fuel tank.

B: INSTALLATION

Install in the reverse order of removal.

NOTE:

Use a new gasket and retainer.

- (1) Ensure the sealing portion is free from fuel or foreign particles before installation.
- (2) Tighten the nuts in alphabetical sequence shown in figure to specified torque.

Tightening torque:

4.4 N·m (0.45 kgf-m, 3.3 ft-lb)

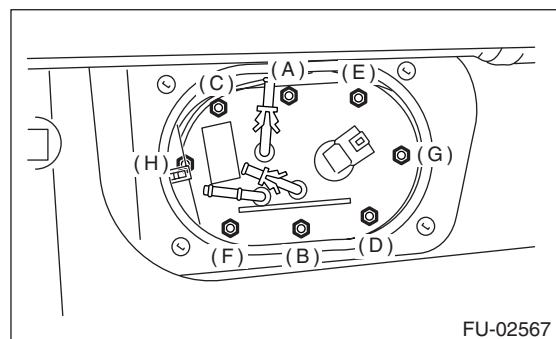

C: INSPECTION

Connect the lead harness to the connector terminal of fuel pump and apply the battery power supply to check whether the pump operates.

WARNING:

- Wipe off the fuel completely.
- Keep battery as far apart from fuel pump as possible.
- Be sure to turn the battery supply ON and OFF on the battery side.
- Do not run fuel pump for a long time under non-load condition.

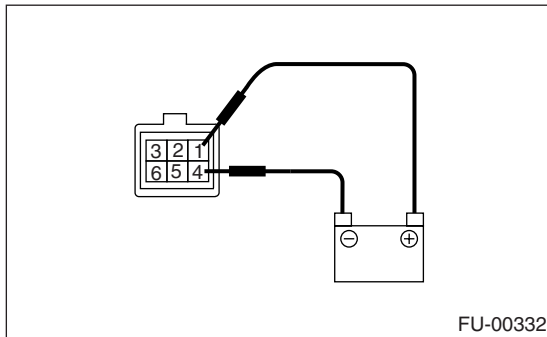

Fuel Level Sensor

FUEL INJECTION (FUEL SYSTEMS)

26. Fuel Level Sensor

A: REMOVAL

WARNING:

- Place “NO FIRE” signs near the working area.
- Be careful not to spill the fuel.

NOTE:

Fuel level sensor is built in fuel pump assembly.

- 1) Remove the fuel pump assembly. <Ref. to FU(H4DOTC)-58, REMOVAL, Fuel Pump.>
- 2) Disconnect the connector from the fuel pump bracket.

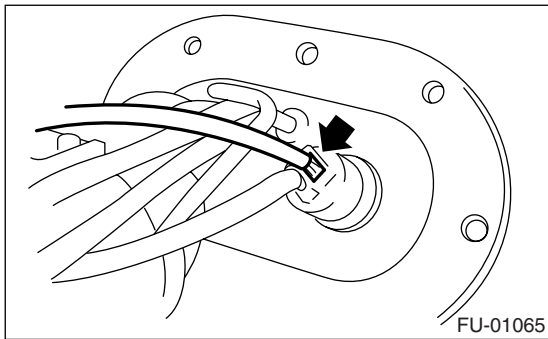

- 3) Remove the fuel temperature sensor.

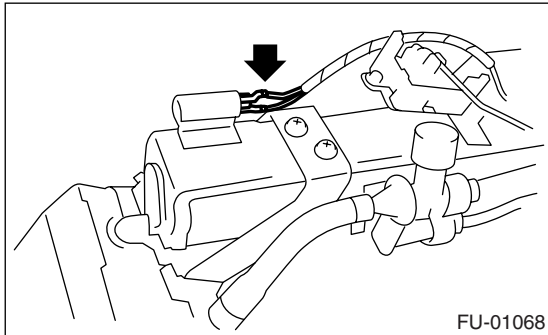

- 4) Remove the bolt which installs the fuel level sensor on mounting bracket.

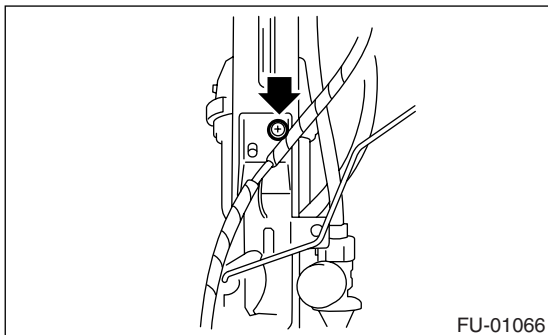

B: INSTALLATION

Install in the reverse order of removal.

27. Fuel Sub Level Sensor

A: REMOVAL

WARNING:

- Place “NO FIRE” signs near the working area.
- Be careful not to spill fuel on the floor.

- 1) Disconnect the ground cable from battery.
- 2) Lift up the vehicle.
- 3) Drain the fuel from the fuel tank. <Ref. to FU(H4DOTC)-50, DRAINING FUEL, PROCEDURE, Fuel.>
- 4) Remove the luggage floor mat. <Ref. to EI-61, REMOVAL, Luggage Floor Mat.>
- 5) Remove the service hole cover.

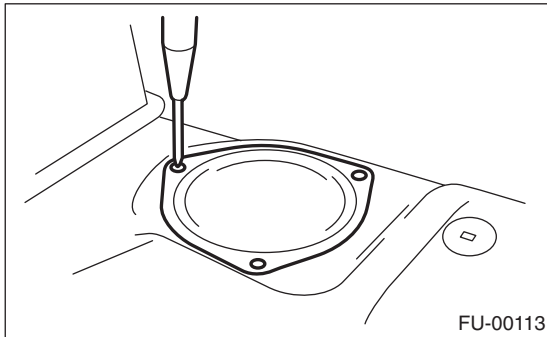

- 6) Disconnect the connector from the fuel sub level sensor.
- 7) Disconnect the fuel jet pump hose.

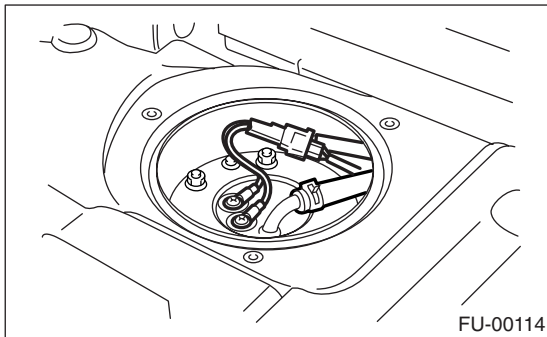

- 8) Remove the bolts which install the fuel sub level sensor on the fuel tank.

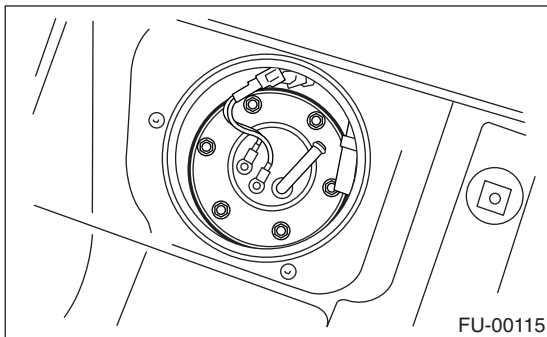

- 9) Remove the fuel sub level sensor.

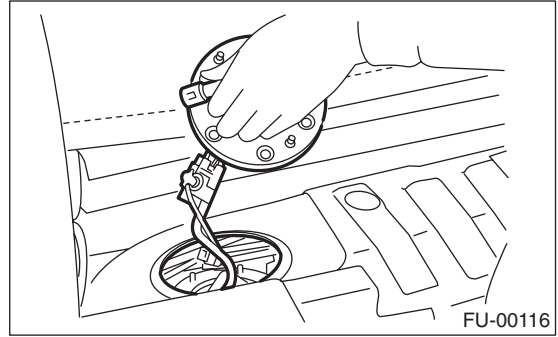

B: INSTALLATION

Install in the reverse order of removal.

NOTE:

Use a new gasket.

- (1) Ensure the sealing portion is free from fuel or foreign particles before installation.
- (2) Tighten the nuts and bolts to specified torque in the order as shown in the figure.

Tightening torque:

4.4 N·m (0.45 kgf·m, 3.3 ft·lb)

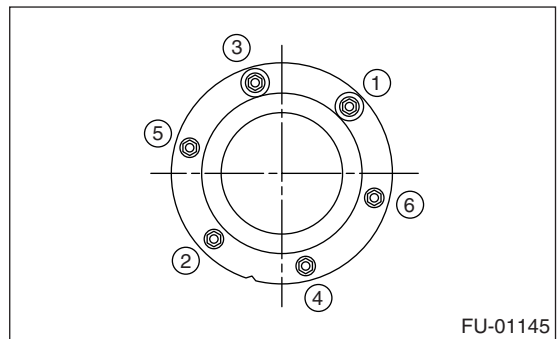

Fuel Filter

FUEL INJECTION (FUEL SYSTEMS)

28. Fuel Filter

A: REMOVAL

WARNING:

- Place “NO FIRE” signs near the working area.
- Be careful not to spill the fuel.

NOTE:

Fuel filter is built into the fuel pump assembly.

- 1) Release the fuel pressure. <Ref. to FU(H4DOTC)-50, RELEASING OF FUEL PRESSURE, PROCEDURE, Fuel.>
- 2) Remove the fuel pump assembly. <Ref. to FU(H4DOTC)-58, REMOVAL, Fuel Pump.>
- 3) Remove the fuel pump. <Ref. to FU(H4DOTC)-58, REMOVAL, Fuel Pump.>
- 4) Separate the fuel filter from fuel pump.

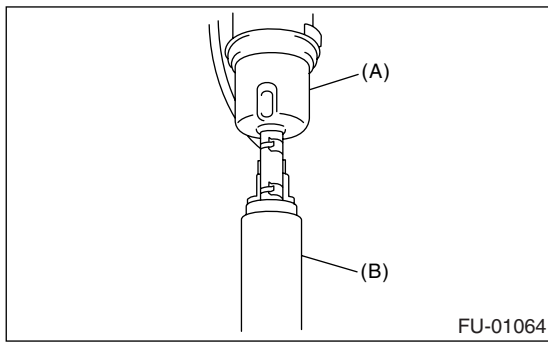

- (A) Fuel filter
(B) Fuel pump

- 5) Turn the filter holder around to the arrow direction, and then remove the filter.

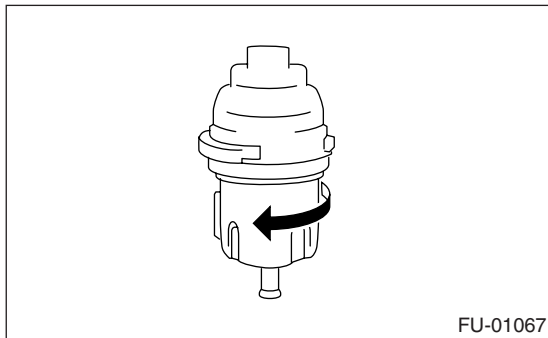

B: INSTALLATION

CAUTION:

- If fuel hoses are damaged at the connecting portion, replace them with new ones.
- If clamps are badly damaged, replace them with new ones.

Install in the reverse order of removal.

C: INSPECTION

- 1) Check the inside of fuel filter for dirt and water sediment.
- 2) If it is clogged, or if replacement interval has been reached, replace it.

29. Fuel Cut Valve

A: REMOVAL

- 1) Remove the fuel tank. <Ref. to FU(H4DOTC)-51, REMOVAL, Fuel Tank.>
- 2) Remove the protect cover.

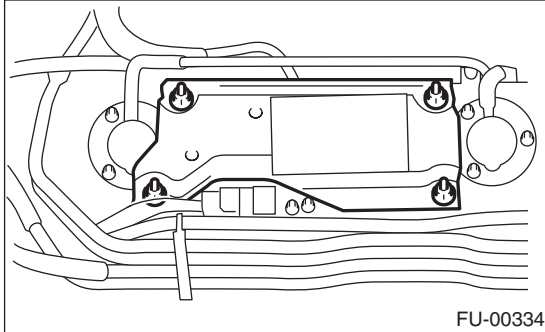

- 3) Move the clip and disconnect the evaporation hose from fuel cut valve.

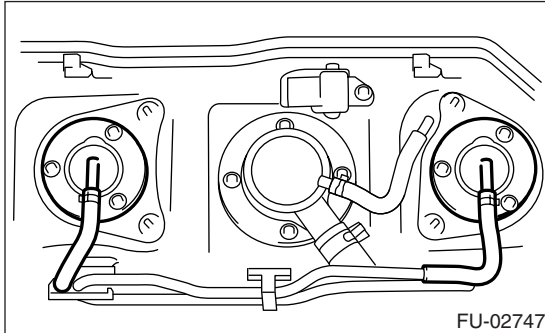

- 4) Remove the bolts which install the fuel cut valve.

B: INSTALLATION

Install in the reverse order of removal.

NOTE:

Use a new gasket.

Tightening torque:

4.4 N·m (0.45 kgf-m, 3.3 ft-lb)

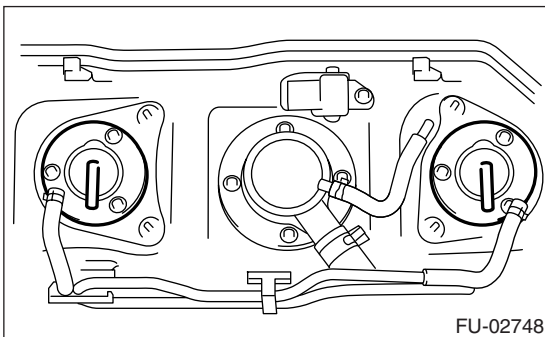

30. Fuel Damper Valve

A: REMOVAL

1) Release the fuel pressure. <Ref. to FU(H4DOTC)-50, RELEASING OF FUEL PRESSURE, PROCEDURE, Fuel.>

2) Remove the fuel damper valve from the fuel delivery line (A) and fuel return line (B).

WARNING:

- Be careful not to spill fuel.
- Catch the fuel from hoses using a container or cloth.

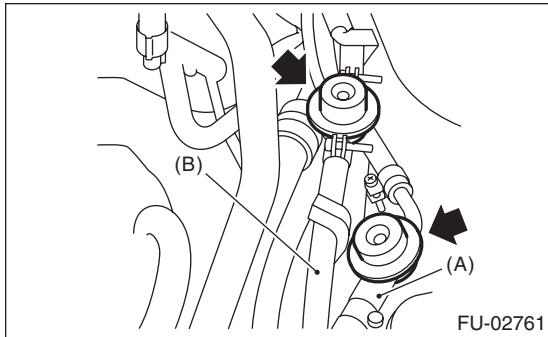

B: INSTALLATION

Install in the reverse order of removal.

Tightening torque:

1.25 N·m (0.13 kgf-m, 0.94 ft-lb)

31. Fuel Delivery, Return and Evaporation lines

A: REMOVAL

- 1) Set the vehicle on a lift.
- 2) Release the fuel pressure. <Ref. to FU(H4DOTC)-50, RELEASING OF FUEL PRESSURE, PROCEDURE, Fuel.>
- 3) Open the fuel filler flap lid and remove the fuel filler cap.
- 4) Remove the floor mat. <Ref. to EI-60, REMOVAL, Floor Mat.>
- 5) Disconnect the fuel delivery pipes and hoses, and disconnect the fuel return pipes and hoses, evaporation pipes and hoses.

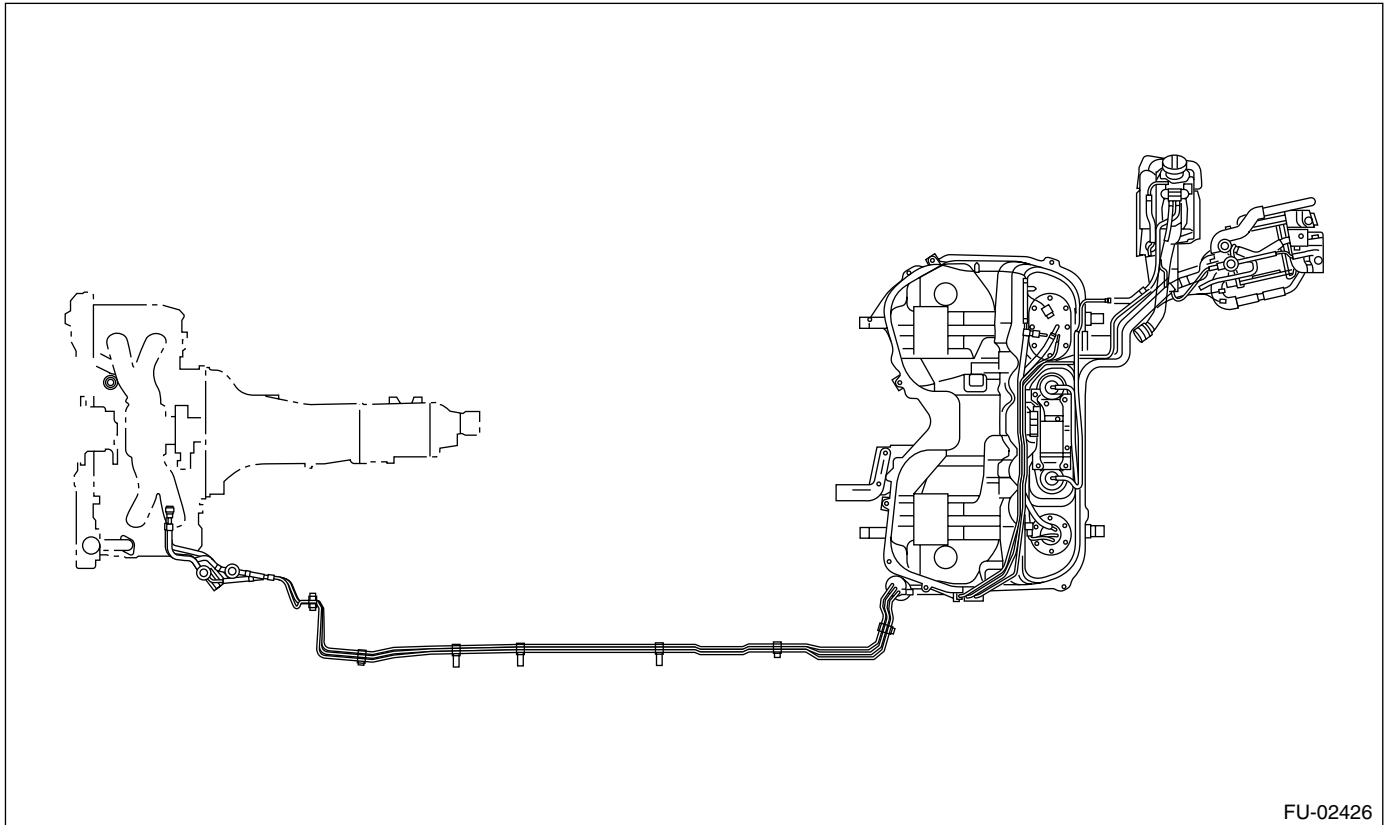

6) In engine compartment, detach the fuel delivery hoses, return hoses and evaporation hose.

- (1) Disconnect the quick connectors of fuel delivery line and return line by pushing the ST to the direction of arrow.

ST 42099AE000 CONNECTOR REMOVER

- (2) Remove the clip, and disconnect the evaporation hose from pipe.

WARNING:

- Be careful not to spill fuel.
- Catch the fuel from hoses using a container or cloth.

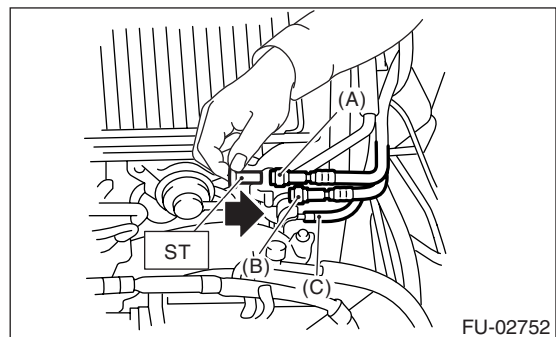

- (A) Fuel delivery hose
- (B) Return hose
- (C) Evaporation hose

7) Lift up the vehicle.

Fuel Delivery, Return and Evaporation lines

FUEL INJECTION (FUEL SYSTEMS)

8) Disconnect the quick connector on fuel line.

- (1) Clean the pipe and connector, if they are covered with dust.
- (2) To prevent from damaging or entering foreign matter, wrap the pipes and connectors with plastic bag, etc.

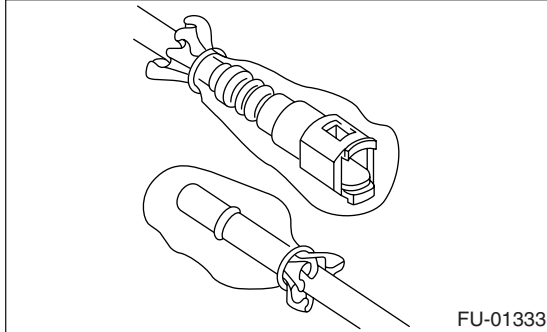

(3) Hold the connector (A) and push retainer (B) down.

(4) Pull out the connector (A) from retainer (B).

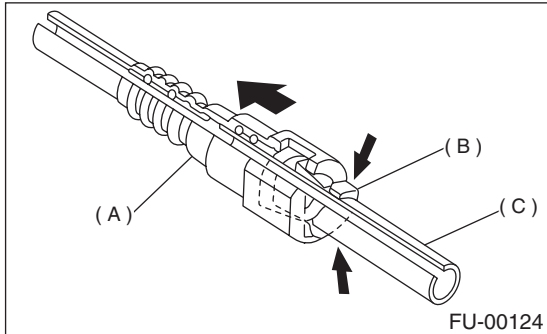

- (A) Connector
- (B) Retainer
- (C) Pipe

B: INSTALLATION

1) Connect the quick connector on fuel line.

CAUTION:

- Use a new retainer except for use of engine compartment.

- Make sure that the connected portion is not damaged or has dust. If necessary, clean seal surface of pipe.

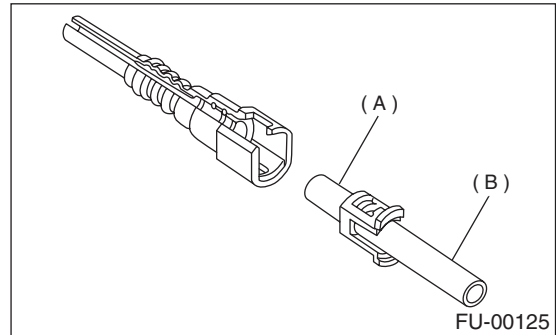

- (A) Seal surface
- (B) Pipe

- (1) Set the new retainer (B) to connector (A).
- (2) Push the pipe into the connector completely.

NOTE:

At this time, two clicking sounds are heard.

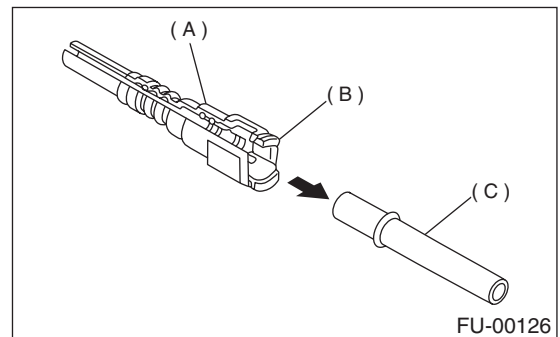

- (A) Connector
- (B) Retainer
- (C) Pipe

CAUTION:

- Pull the connector to ensure it is connected securely.
- Ensure the two retainer pawls are engaged in their mating positions in the connector.

Fuel Delivery, Return and Evaporation lines

FUEL INJECTION (FUEL SYSTEMS)

- Be sure to inspect hoses and their connections for any leakage of fuel.

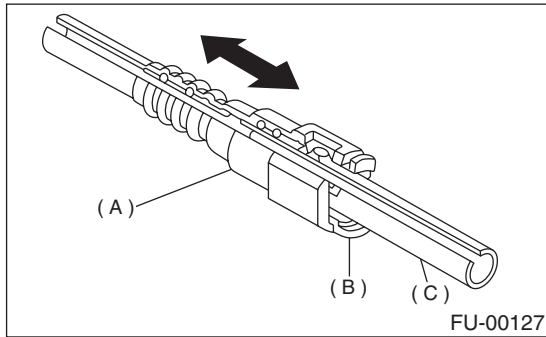

- (A) Connector
- (B) Retainer
- (C) Pipe

2) Connect the fuel delivery hose and return hose by inserting them into the pipe for 20 to 25 mm (0.79 to 0.98 in) in length.

Type A: When the fitting length is specified.

Type B: When the fitting length is not specified.

$\varnothing : 2.5 \pm 1.5 \text{ mm } (0.098 \pm 0.059 \text{ in})$

$L : 22.5 \pm 2.5 \text{ mm } (0.886 \pm 0.098 \text{ in})$

CAUTION:

Be sure to inspect hoses and their connections for any leakage of fuel.

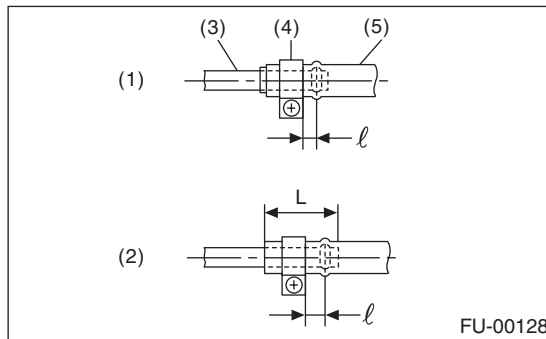

- (1) Type A
- (2) Type B
- (3) Pipe
- (4) Clamp
- (5) Hose

3) Connect the evaporation hose by inserting it into the pipe for 15 to 20 mm (0.59 to 0.79 in) in length.

$L = 17.5 \pm 2.5 \text{ mm } (0.689 \pm 0.098 \text{ in})$

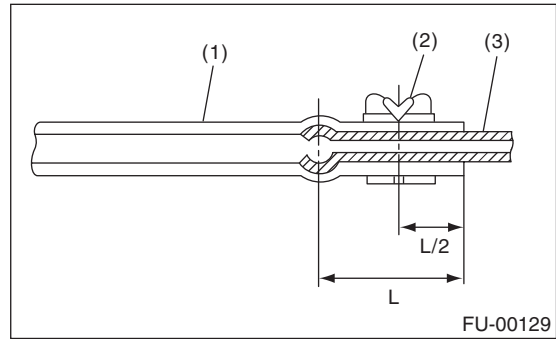

- (1) Hose
- (2) Clip
- (3) Pipe

C: INSPECTION

1) Make sure that there are no cracks on the fuel pipes and fuel hoses.

2) Make sure that the fuel pipe and fuel hose connections are tight.

Fuel System Trouble in General

FUEL INJECTION (FUEL SYSTEMS)

32. Fuel System Trouble in General

A: INSPECTION

Trouble and possible cause		Corrective action
1. Insufficient fuel supply to injector		
1)	Fuel pump does not operate.	
	○ Defective terminal contact.	Inspect contact, especially ground, and tighten it securely.
	○ Trouble in electromagnetic or electronic circuit parts.	Replace the faulty parts.
2)	Lowering of fuel pump function.	Replace the fuel pump.
3)	Clogged dust or water in the fuel filter.	Replace fuel filter, clean or replace fuel tank.
4)	Clogged or bent fuel pipe or hose.	Clean, correct or replace the fuel pipe or hose.
5)	Air is mixed in the fuel system.	Inspect or retighten each connection part.
6)	Clogged or bent air breather tube or pipe.	Clean, correct or replace air breather tube or pipe.
7)	Damaged diaphragm of pressure regulator.	Replace.
2. Leakage or blow out of fuel		
1)	Loosened joints of the fuel pipe.	Retightening.
2)	Cracked fuel pipe, hose and fuel tank.	Replace.
3)	Defective welding part on the fuel tank.	Replace.
4)	Defective drain packing of the fuel tank.	Replace.
5)	Clogged air breather tube or air vent tube.	Clean, correct or replace air breather tube or air vent tube.
3. Gasoline smell inside of compartment		
1)	Loose joints at air breather tube, air vent tube and fuel filler pipe.	Retightening.
2)	Defective packing air tightness on the fuel saucer.	Correct or replace the packing.
3)	Inoperative fuel pump modulator or circuit.	Replace.
4. Defective fuel meter indicator		
1)	Defective operation of fuel level sensor.	Replace.
2)	Defective operation of fuel meter.	Replace.
5. Noise		
1)	Large operation noise or vibration of fuel pump.	Replace.

NOTE:

- When the vehicle is left unattended for an extended period of time, water may accumulate in the fuel tank. Fill fuel fully to prevent those problem. And also drain the water condensation from fuel filter.
- In snow-covered areas, mountainous areas, skiing areas, etc. where ambient temperatures drop below 0°C (32°F) throughout the winter season, use water removing agent in the fuel system to prevent freezing fuel system and accumulating water. Fill the water removing agent at the time when the fuel reduced at half to maintain the advantage.
- When water condensation is noticed in the fuel filter, drain the water from both the fuel filter and fuel tank or use water removing agent in the fuel tank.
- Before using a water removing agent, follow the cautions that noted on the bottle.